

Section Da.4

CARBURETTERS (Engine Type 12V 778F)

Tuning

Before tuning the carburetters in an endeavour to rectify poor engine performance, check the following items to ensure that the maladjustment or fault is not from another source.

- (a) Valve clearance.
- (b) Spark plug condition.
- (c) Contact breaker (dwell angle).
- (d) Ignition timing and advance.
- (e) Presence of air leaks in the induction system.
- (f) Operation of engine controls.

Carburetter tuning is confined to setting the idle and fast idle speeds, and mixture at idle speed. To achieve the best results, a reliable tachometer, a balancing meter and an exhaust gas analyser (CO meter of the infra-red non-dispersive type or equivalent) are required.

- (1) Remove the air cleaners as detailed in Section D.6.
- (2) Check the throttle for correct operation and signs of sticking.
- (3) Unscrew each throttle adjusting screw until it is just clear of the throttle lever stop when the throttle is closed, then turn each screw one turn in a clockwise direction.
- (4) Raise the piston of each carburetter, using the lifting pin, and check that the piston falls freely onto the bridge in the carburetter body when the lifting pin is released. If the piston tends to stick, the carburetter must be serviced.
- (5) Lift and support the piston of each carburetter clear of the bridge in the carburetter body so that each carburetter jet is visible.
- (6) Turn the jet adjusting nut of each carburetter upwards until each jet is flush with the bridge in the carburetter body or as high as possible without exceeding the bridge height. Ensure that both jets are in the same relative position to the bridge of their respective carburetter.
- (7) Check that the shank of each needle is flush with the underside of its respective piston.
- (8) Turn the jet adjusting nut of each carburetter two turns downwards.
- (9) Turn the fast idle adjusting screw of each carburetter in an anti-clockwise direction until it is well clear of its fast idle cam.
- (10) Unscrew and withdraw the piston dampers from the suction chambers. Top up with new engine oil (preferably S.A.E. 20) until the level is $\frac{1}{2}$ in.

13 mm.) above the top of each hollow piston rod. Refit the damper assemblies.

- (11) Connect the tachometer of tool 18G 677 Z to the engine.
- (12) Start the engine and run it at a fast idle until it attains normal running temperature, then run it for a further five minutes.
- (13) Increase the engine speed to 2,500 r.p.m. for 30 seconds.
- (14) Connect an exhaust gas analyser to the engine in accordance with the instrument manufacturer's instructions.

Setting can now commence. If the correct setting cannot be obtained within three minutes, increase the engine speed to 2,500 r.p.m. for 30 seconds and then recommence tuning. Repeat this clearing operation at three-minute intervals until tuning is completed.

- (15) Slacken the two throttle inter-connecting rod lever clamping bolts.
- (16) Slacken the two jet inter-connecting rod lever clamping bolts.
- (17) Using a balance meter in accordance with the manufacturer's instructions, balance the carburetters, altering the throttle adjusting screws until the correct idle speed (see 'ENGINE TUNING DATA') and balance is achieved. Alternatively, use a 'listening tube' to compare the intensity of the intake hiss from both carburetters and alter the throttle adjusting screws until the hiss from both carburetters is the same at idling speed.
- (18) Turn the jet adjusting nut of each carburetter by the same amount, downwards to enrich or upwards to weaken, until the fastest engine speed is indicated on the tachometer; turn each nut upwards by the same amount until the engine speed just commences to fall. Turn each nut very slowly downwards by the minimum but same amount until the maximum engine speed is regained.
- (19) Check the engine idling speed and re-adjust it as necessary, turning each throttle adjusting screw by the same amount.
- (20) Using the exhaust gas analyser, check that the carbon monoxide percentage is within the limits given in 'ENGINE TUNING DATA'. If the reading falls outside the limits, reset both jet adjusting nuts by the same minimum amount necessary to bring the reading just within the limits. If an adjustment exceeding three flats of the jet adjusting nuts is required to achieve this, the carburetters must be removed and serviced.

APPENDIX

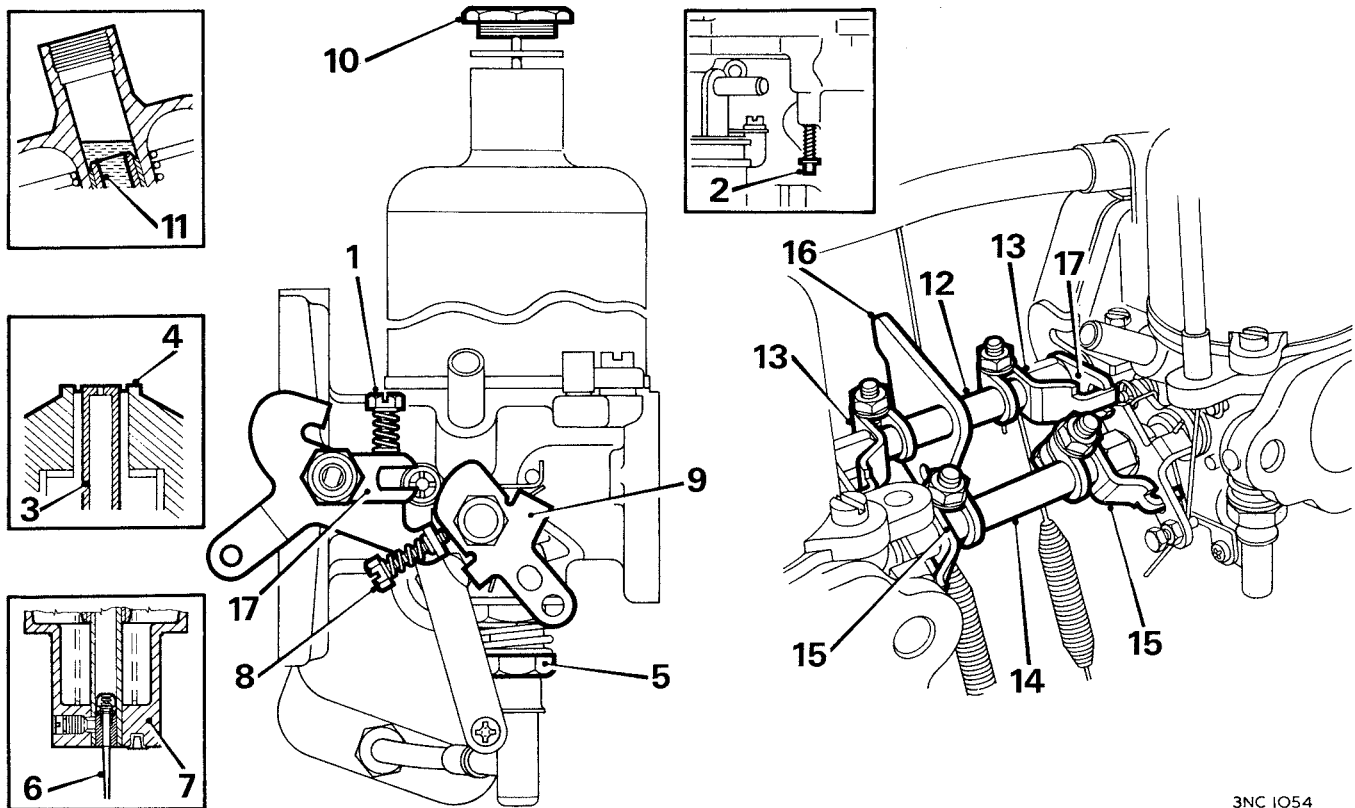

3NC 1054

Fig. Da.9
Carburettor tuning

- | | | |
|------------------------------|------------------------------------|---|
| 1. Throttle adjusting screw. | 7. Piston. | 13. Throttle inter-connection rod lever. |
| 2. Piston lifting pin. | 8. Fast idle adjusting screw. | 14. Jet inter-connecting rod. |
| 3. Jet. | 9. Fast idle cam lever. | 15. Jet inter-connecting rod lever. |
| 4. Bridge. | 10. Piston damper. | 16. Throttle inter-connecting rod stop lever. |
| 5. Jet adjusting nut. | 11. Piston rod. | 17. Throttle lever. |
| 6. Jet needle. | 12. Throttle inter-connecting rod. | |

- (21) Stop the engine and set the throttle inter-connecting rod levers so that a clearance of 0.012 in. (0.31 mm.) exists between each lever link pin and the lower arm of its respective throttle lever fork.
- (a) Insert a 0.012 in. (0.31 mm.) feeler gauge between the throttle inter-connecting rod stop lever and the carburettor heat shield.
- (b) Move each throttle inter-connector lever downwards until each lever link pin rests on the lower arm of its respective throttle lever fork. Tighten the throttle inter-connecting rod lever clamp bolts, ensuring that the throttle inter-connecting rod has an end-float of approximately $\frac{3}{32}$ in. (0.8 mm.). Remove the feeler gauge.
- (22) Run the engine at 1,500 r.p.m. and re-check the carburettor balance to ensure that the throttle linkage is connected correctly.
- (23) Ensure that the fast idle cam lever of each carburettor is against its respective stop and tighten the jet inter-connecting rod lever clamp bolts so that both cam levers begin to move simultaneously when the mixture control is operated.
- (24) Ensure that the fast idle cam lever of each carburettor is against its respective stop and check that the mixture control cable has $\frac{1}{16}$ in (1.5 mm.) free movement before it commences to operate the cam levers.
- (25) Pull the mixture control out until the jet linkage is about to move both jets downwards.
- (26) Run the engine and using the balance meter or 'listening tube' to ensure equal adjustment, turn the fast idle adjusting screws to set the engine fast idling to the speed given in 'ENGINE TUNING DATA'.
- (27) Refit the air cleaners.

Section Db.5

FUEL PUMP (S.U. Type AUF 305)

Removing and refitting

- (1) Disconnect the battery earth lead.
- (2) Drain the fuel from the tank, or plug the pump inlet hose after disconnecting it from the fuel pump.
- (3) Disconnect the fuel inlet and outlet hoses from the unions on the pump body.
- (4) Remove the two strap securing bolts and nuts to release the pump from its mounting bracket on the underside of the luggage boot.
- (5) Disconnect the supply and earth leads from the terminals on the pump.
- (6) Disconnect the vent pipes from the connections on the pump coil housing and the vent valve on the pump end-cover.
- (7) Remove the mounting rubber from the pump.
- (8) Refitting is a reversal of the foregoing procedure.

Dismantling

Contact breaker

- (1) Follow the instructions given in Section Da.1.

Coil housing and diaphragm

- (2) Follow the instructions given in Section Da.1, noting the joint washer between the diaphragm and the pump body.

Pedestal and rocker

- (3) Follow the instructions given in Section Da.1, noting that the contact blade screw secures one of the condenser tags together with one of the coil tags, and that one of the pedestal screws secures the other tag of the condenser together with the earthing tag.

Body and valves

- (4) Remove the two screws securing the inlet and outlet valve clamp plate and withdraw the valve caps, valves, valve seating washers and the fuel filter from the pump body.
- (5) Unscrew the four screws to release the flow-smoothing device cover and withdraw the 'O' ring, diaphragm, and sealing washer from the pump body.
- (6) Remove the screw to release the inlet air bottle cover and its joint washer from the pump body.

Inspection

- (7) Follow the instructions given in Section Da.1, with the following additions.

- (a) Examine the components of the delivery flow-smoothing device for damage. If the condition of the diaphragm is doubtful it must be renewed.
- (b) Examine the inlet air bottle cover and its joint washer for damage.

Reassembly

Pedestal and rocker

- (8) Follow the instructions given in Section Da.1, noting that the pedestal to coil housing screw spring washer is dispensed with and is replaced by one of the condenser leads.

Diaphragm assembly

- (9) Follow the instructions given in Section Da.1.

Body components

- (10) Fit the outlet valve joint washer, the outlet valve with its tongue side downwards and the valve cap, into the shallower of the two recesses in the pump body.
- (11) Fit the inlet valve components into the deeper of the two recesses in the pump body, in the following order: joint washer, fuel filter with its domed side downwards, joint washer, inlet valve with its tongue side upwards, and valve cap.
- (12) Ensure that both valve assemblies are properly seated in their recesses, and refit the valve clamp plate and screws.
- (13) Refit the inlet air bottle cover components.
- (14) Fit the delivery flow-smoothing device sealing washer followed by the diaphragm with its concave side uppermost, 'O' ring and cover.

Body attachment

- (15) Fit the pumping diaphragm joint washer to the pump body, align the screw holes then follow the instructions given in Section Da.1.

Contact blade

- (16) Follow the instructions given in Section Da.1, noting that the screw securing the coil lead secures one of the condenser leads.

Contact gap setting

- (17) Follow the instructions given in Section Da.1.

End-cover

- (18) Follow the instructions given in Section Da.1.

Testing on a test stand

- (19) Follow the instructions given in Section Da.1, noting that the pump minimum delivery is 120 pints (144 U.S. pts., 68 litres) per hour.

APPENDIX

THE FUEL PUMP COMPONENTS (S.U. Type AUF 305)

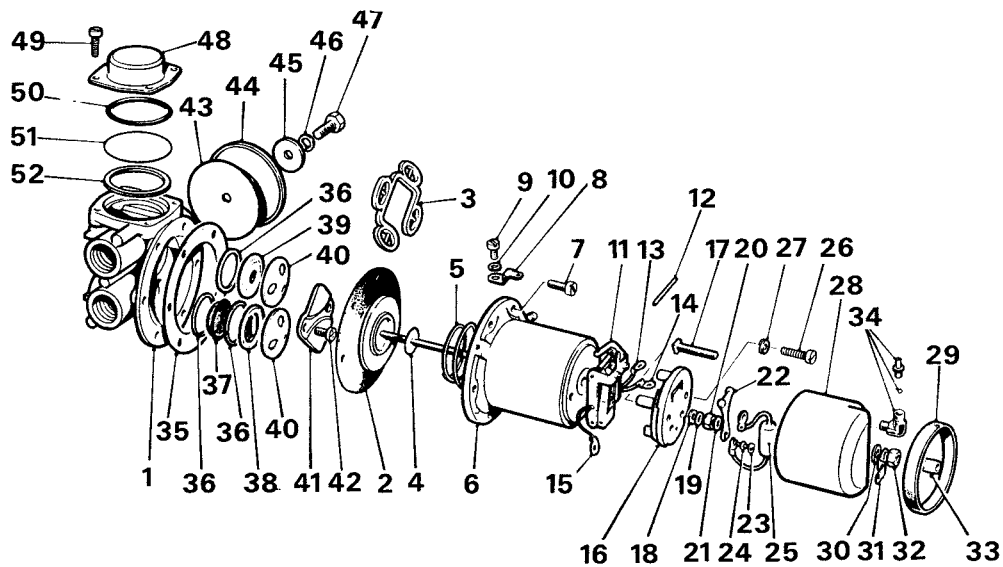

3NC 691A

| No. | Description | No. | Description | No. | Description |
|-----|---------------------------------|-----|----------------------------------|-----|------------------------------|
| 1. | Pump body. | 19. | Lead washer. | 36. | Sealing washer. |
| 2. | Diaphragm and spindle assembly. | 20. | Terminal nut—2 B.A. | 37. | Inlet filter. |
| 3. | Armature guide plate. | 21. | Sealing washer—end cover. | 38. | Inlet valve. |
| 4. | Impact washer. | 22. | Contact blade. | 39. | Outlet valve. |
| 5. | Armature spring. | 23. | Screw—5 B.A. | 40. | Valve cap. |
| 6. | Coil housing. | 24. | Washer. | 41. | Clamp plate. |
| 7. | Screw—housing to body—2 B.A. | 25. | Condenser. | 42. | Screw—plate to body. |
| 8. | Connector—earth. | 26. | Screw—pedestal to housing—2 B.A. | 43. | Joint—inlet air bottle. |
| 9. | Screw—4 B.A. | 27. | Spring washer. | 44. | Cover—inlet air bottle. |
| 10. | Spring washer. | 28. | End cover. | 45. | Dished washer. |
| 11. | Rocker mechanism. | 29. | Sealing band. | 46. | Spring washer. |
| 12. | Rocker pivot pin. | 30. | Shakeproof washer. | 47. | Screw—cover to body. |
| 13. | Terminal tag—5 B.A. | 31. | Connector—feed. | 48. | Cover—flow smoothing device. |
| 14. | Terminal tag—2 B.A. | 32. | Nut—2 B.A. | 49. | Screw—cover to body. |
| 15. | Earth tag—2 B.A. | 33. | Insulating sleeve. | 50. | 'O' ring seal. |
| 16. | Pedestal. | 34. | One-way vent valve. | 51. | Diaphragm. |
| 17. | Terminal stud. | 35. | Gasket—diaphragm to body. | 52. | Sealing washer. |
| 18. | Spring washer. | | | | |

Section Nb. 9

SWITCHES, WARNING LAMPS AND CONTROLS (Midget Mk. III from Car No. G-AN5-123731)

NOTE.—Refer to Section Nb.1 for the removal and refitting of the instruments and steering-column switches.

Removing

IMPORTANT.—Disconnect the battery before attempting to remove any of the switches, warning lamps or controls.

Heater blower switch

- (1) Remove the bulb holder from the switch retainer.
- (2) Disconnect the wiring from the switch.
- (3) Remove the retainer from the switch and withdraw the switch from the fascia.

Lighting switch

- (4) Remove the centre console—Section Rb.1.
- (5) Remove the bulb holder from the switch retainer.
- (6) Disconnect the wiring from the switch.
- (7) Remove the retainer from the switch and withdraw the switch from the fascia.

APPENDIX

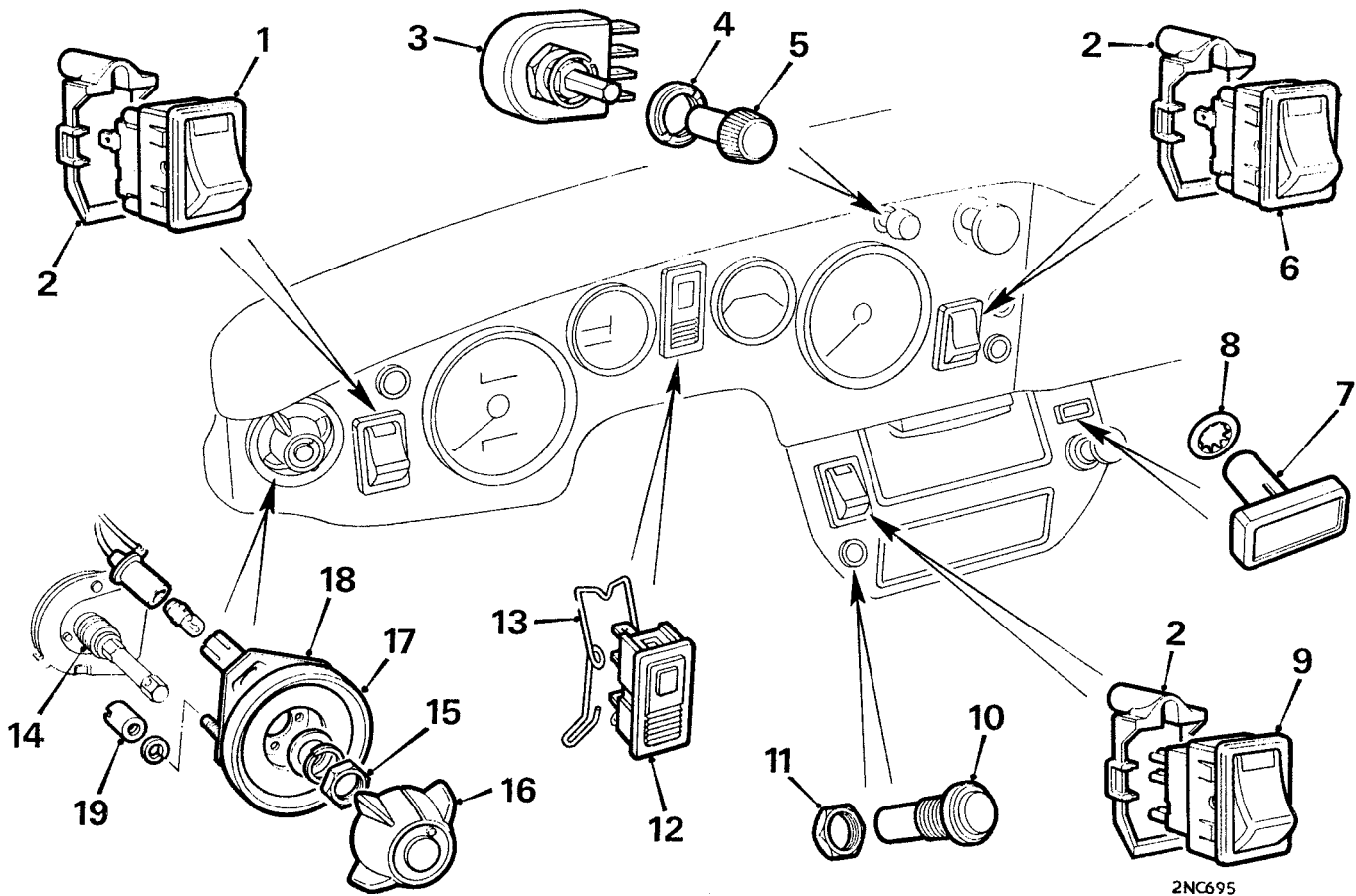

Fig. Nb.5

The switches, lamps and controls (Midget Mk. III from Car No. 123731)

- | | | |
|---|---|---|
| <ul style="list-style-type: none"> 1. Heater blower switch. 2. Retainer for switch. 3. Panel lamp rheostat switch. 4. Retainer for rheostat switch. 5. Knob for panel lamp rheostat switch. 6. Lighting switch. 7. Seat belt warning lamp. | <ul style="list-style-type: none"> 8. Retainer for seat belt warning lamp. 9. Hazard warning switch. 10. Hazard warning lamp. 11. Retainer for hazard warning lamp. 12. Brake pressure—warning light test-push. 13. Retaining clip. | <ul style="list-style-type: none"> 14. Rotary control. 15. Retaining nut. 16. Rotary control knob. 17. Dial assembly. 18. Light box. 19. Retaining nut. |
|---|---|---|

Hazard warning switch

- (8) Remove the centre console—Rb.1.
- (9) Withdraw the bulb holder from the switch retainer.
- (10) Disconnect the wiring plug from the switch.
- (11) Remove the retainer from the switch and withdraw the switch from the console.

Panel lamp rheostat switch

- (12) Remove the centre console—Section Rb.1.
- (13) Disconnect the wiring from the switch.
- (14) Depress the pin in the switch knob and withdraw the knob from the switch.
- (15) Unscrew the switch retainer and remove the switch from the fascia.

Seat belt warning lamp

- (16) Remove the centre console—Section Rb.1.
- (17) Remove the bulb holder from the warning lamp.
- (18) Remove the warning lamp clip retainer and push the warning lamp out of the centre console.

Hazard warning lamp

- (19) Remove the centre console—Section Rb.1.
- (20) Remove the bulb holder from the warning lamp.
- (21) Unscrew the warning lamp retainer and remove the warning lamp from the centre console.

Air-flow rotary control

- (22) Depress the pin in the rotary control knob and withdraw the knob from the spindle.
- (23) Remove the bulb holder from the rotary control light box.
- (24) Unscrew the nut retaining the rotary control to the fascia and remove the spring and plain washer.
- (25) Remove the rotary control from the fascia.
- (26) Unscrew the three nuts and remove the three spring and plain washers to release the light box from the dial assembly.
- (27) Remove the dial assembly from the fascia.

Audible warning and courtesy light door switch

- (28) Remove the retaining screw and withdraw the switch.
- (29) Disconnect the wiring from the switch.

Refitting

Heater blower switch

- (30) Reverse the removing procedure in (1) to (3).

Lighting switch

- (31) Reverse the removing procedure in (5) to (7).
- (32) Refit the centre console—Section Rb.1.

Hazard warning switch

- (33) Reverse the removing procedure in (9) to (11).
- (34) Refit the centre console—Section Rb.1.

Panel lamp rheostat switch

- (35) Reverse the removing procedure in (13) to (15).
- (36) Refit the centre console—Section Rb.1.

Seat belt warning lamp

- (37) Reverse the removing procedure in (17) and (18).
- (38) Refit the centre console—Section Rb.1.

Hazard warning lamp

- (39) Reverse the removing procedure in (20) and (21).
- (40) Refit the centre console—Section Rb.1.

Air-flow rotary control

- (41) Reverse the removing procedure in (22) to (27).

Audible warning and courtesy light door switch

- (42) Reverse the removing procedure in (28) and (29).

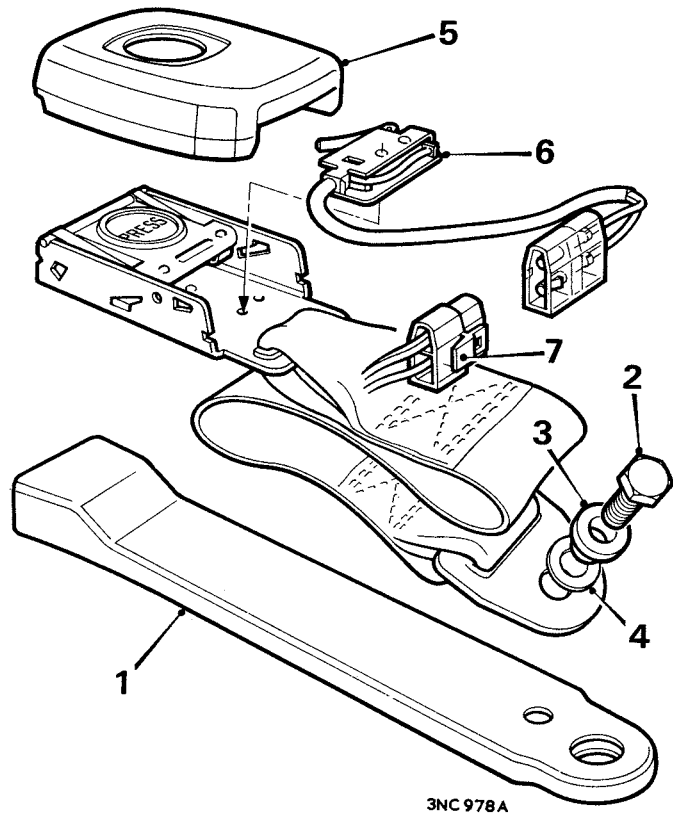

Fig. Nb.6

Seat belt warning lamp and buzzer—seat belt switch

- | | |
|-------------------------|-------------------------------|
| 1. Sleeve. | 5. Switch and buckle cover. |
| 2. Retaining bolt. | 6. Switch. |
| 3. Spacer. | 7. Plug and socket retainers. |
| 4. Bowed spring washer. | |

Section Nb.10

SEAT BELT WARNING LAMP AND BUZZER—SEAT BELT SWITCH

Removing

- (1) Disconnect the battery.
- (2) Remove the bolt to release the seat belt buckle assembly from the floor tunnel.
- (3) Compress the retainers and disconnect the belt switch plug from the wiring harness socket.
- (4) Withdraw the sleeve from the buckle until the sleeve is clear of the belt switch cover.
- (5) Prise the sides of the belt switch cover, at its lower end, away from the buckle and withdraw the switch cover.
- (6) Remove the rivets to release the switch from the seat buckle.
- (7) Unsolder the cables from the switch.

Refitting

- (8) Reverse the procedure in 1 to 7.

Nb.12

Section Nb.11

SEAT BELT WARNING LAMP AND BUZZER—SEAT SWITCH

Removing

- (1) Disconnect the battery.
- (2) Remove the two screws securing the rear of the seat runners to the floor and from beneath the car remove the two nuts securing the front of the seat runners to the floor.
- (3) Compress the retainers and disconnect the seat switch plug from the wiring harness socket. Remove the seat from the car.
- (4) Remove the clips to release the seat cover from the rear and one side of the seat frame.
- (5) Detach the seat strapping and frame from the front, rear and one side of the seat frame.
- (6) Detach the hessian cover from the underside of the seat cushion and withdraw the seat switch.

Refitting

- (7) Reverse the procedure in 1 to 6.

Sprite and Midget. Issue 2. 85737

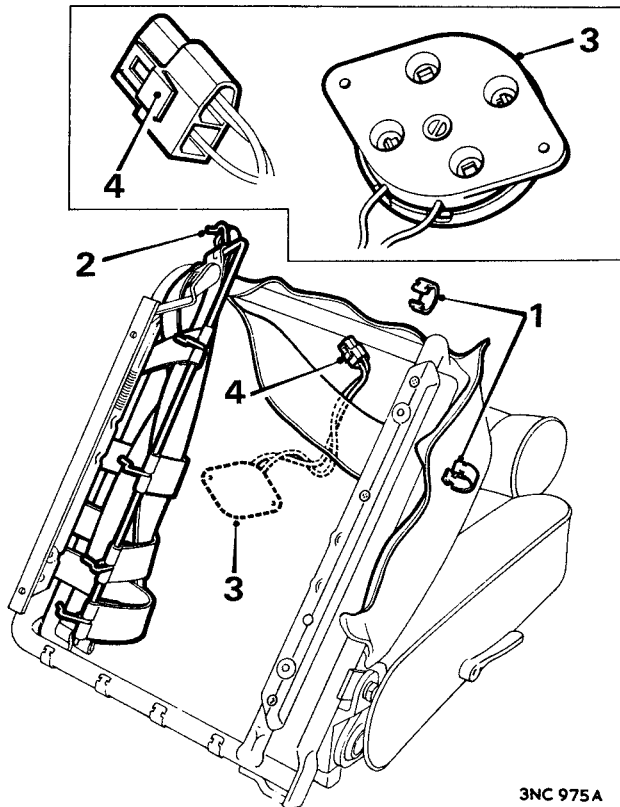

3NC 975A

Fig. Nb.7

Seat belt warning lamp and buzzer—seat switch

- 1. Seat cover clip.
- 2. Seat strapping and frame.
- 3. Switch.
- 4. Plug and socket retainers.

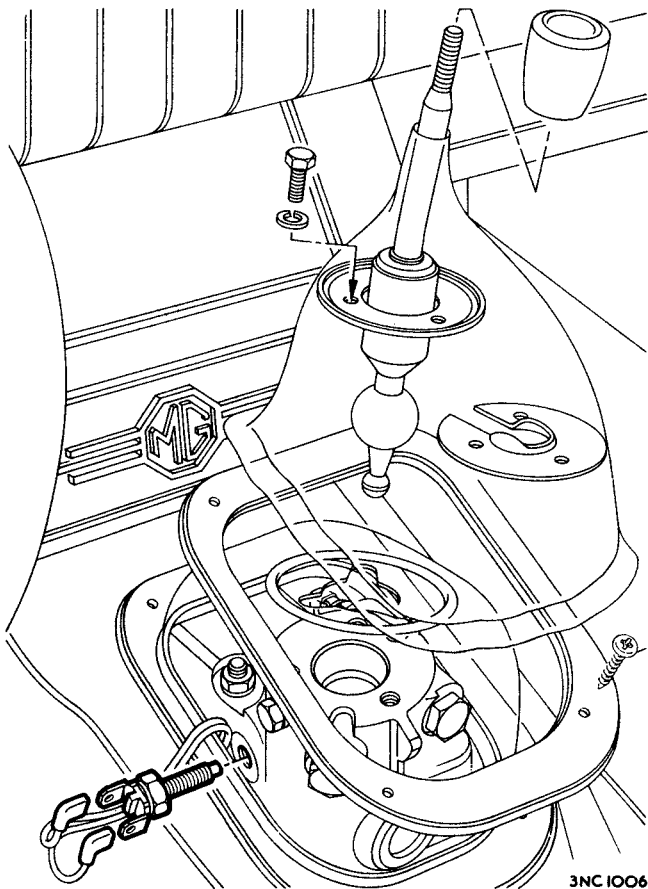

3NC 1006

Fig. Nb.8

Seat belt warning lamp and buzzer—gearbox switch

Section Nb.12

SEAT BELT WARNING LAMP AND BUZZER—GEARBOX SWITCH

Removing

- (1) Disconnect the battery.
- (2) Remove the tunnel front carpet.
- (3) Unscrew the gear lever knob.
- (4) Remove the four screws to release the gaiter retainer from the tunnel and withdraw the fabric gaiter.
- (5) Remove the three bolts to release the gear lever complete with rubber gaiter from the gearbox.
- (6) Disconnect the wiring harness from the two terminal blades on the gearbox switch.
- (7) Partially unscrew the switch from the gearbox, secure the switch with a piece of twine to prevent it falling into the propeller shaft tunnel and completely unscrew the switch from the gearbox.

Refitting

- (8) Reverse the procedure in 1 to 7.

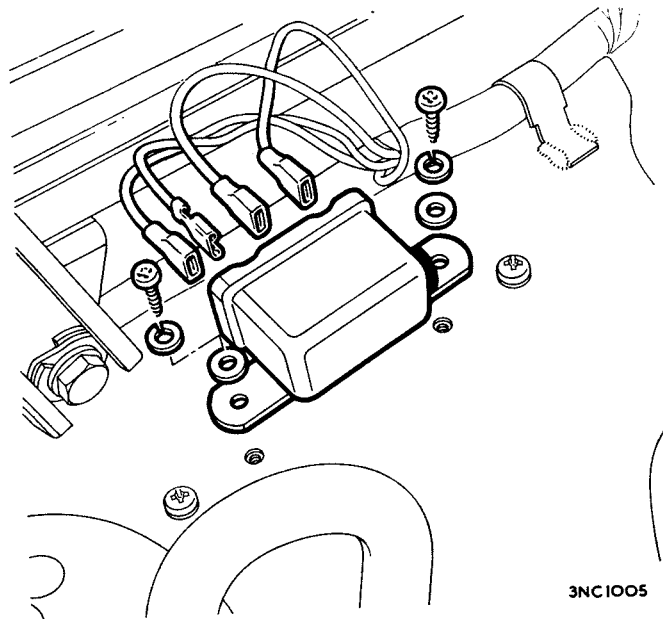

3NC 1005

Fig. Nb.9

Sequential seat belt system—starter motor relay

Section Nb.13

SEQUENTIAL SEAT BELT SYSTEM—STARTER MOTOR RELAY

Removing

- (1) Disconnect the battery.
- (2) Disconnect the wiring harness from the terminal blades on the starter motor relay.
- (3) Remove the two screws to release the starter motor relay from the right hand side of the dash bulkhead panel.

Testing

- (4) Connect a 12-volt direct current supply between the relay terminals 'W1' and 'W2', and a 12-volt, 2.2-watt test lamp in circuit with a 12-volt direct current supply between terminals 'C1' and 'C2'.
 - (a) If the testlamp fails to light, check the relay winding resistance, using an ohmmeter connected between terminals 'W1' and 'W2'. Renew the relay if a reading of 76 ohms is not obtained.
 - (b) If the winding resistance is correct, faulty contact adjustment is indicated which may be corrected as follows:
 - (i) Remove the cover from the relay.
 - (ii) Check the air gap between the relay bobbin core and the underside of the armature. The air gap should be 0.030 ± 0.005 in. (0.76 ± 0.13 mm.) when the contact points are open, and 0.010 ± 0.003 in. (0.25 ± 0.08 mm.) when the points are closed. Bend the fixed contact post as necessary.
- (5) After any adjustment to the air gap, check the relay cut-in and drop-off voltages as follows:
 - (a) Connect a variable direct current supply between the relay terminals 'W1' and 'W2' and a 12-volt direct current supply in circuit with a test lamp between terminals 'C1' and 'C2'.
 - (b) Raise the voltage slowly from zero to 15 volts and check that the test lamp lights at 4.0 to 7.5 volts.
 - (c) Reduce the voltage slowly from 15 to zero volts and check that the test lamp goes out at 5 volts maximum.
 - (d) Repeat operation 4 as necessary, and re-check the relay cut-in and drop-off voltages.
- (6) Refit the relay cover and crimp the cover lip at the points provided.

Refitting

- (7) Reverse the procedure in 1 to 3.

Section Nb.14

SEQUENTIAL SEAT BELT SYSTEM CONTROL UNIT

Removing

- (1) Disconnect the battery.
- (2) Disconnect the demister hose from the right-hand demister duct and the heater.
- (3) Through the aperture in the top of the cubby box, compress the two retaining tags and withdraw the wiring harness plug from the sequential seat belt system control unit.
- (4) Remove the two screws to release the control unit from the dash bulkhead panel.

Refitting

- (5) Reverse the procedure in 1 to 4.

Nb.14

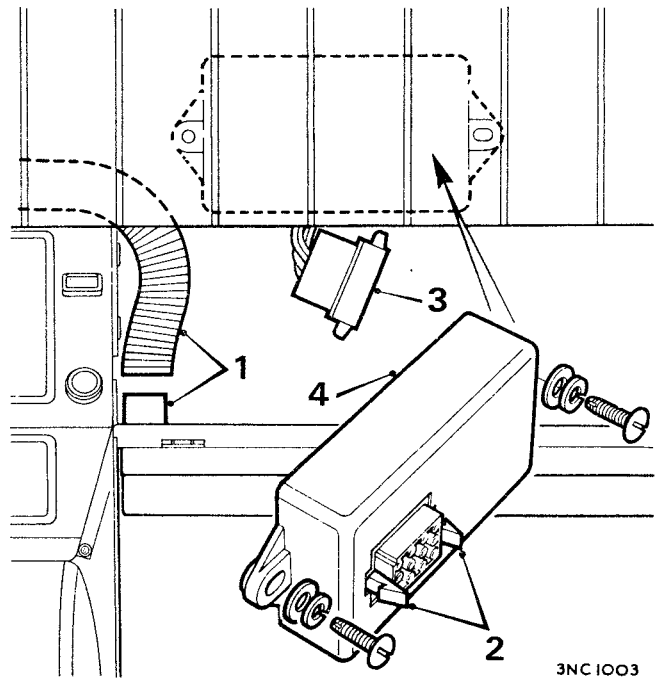

Fig. Nb.10

Sequential seat belt system control unit

- | | |
|--------------------|-------------------------|
| 1. Demister hose. | 3. Wiring harness plug. |
| 2. Retaining tags. | 4. Control unit. |

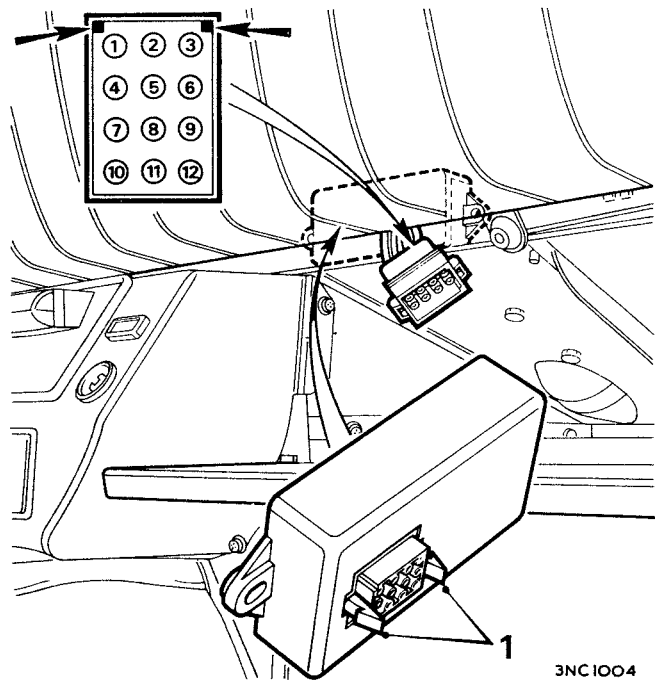

Fig. Nb.11

Sequential seat belt system control unit wiring harness plug pin identification numbers. The arrows indicate the plug polarizing keys. Compress the two retaining tags (1) to withdraw the plug from the control unit

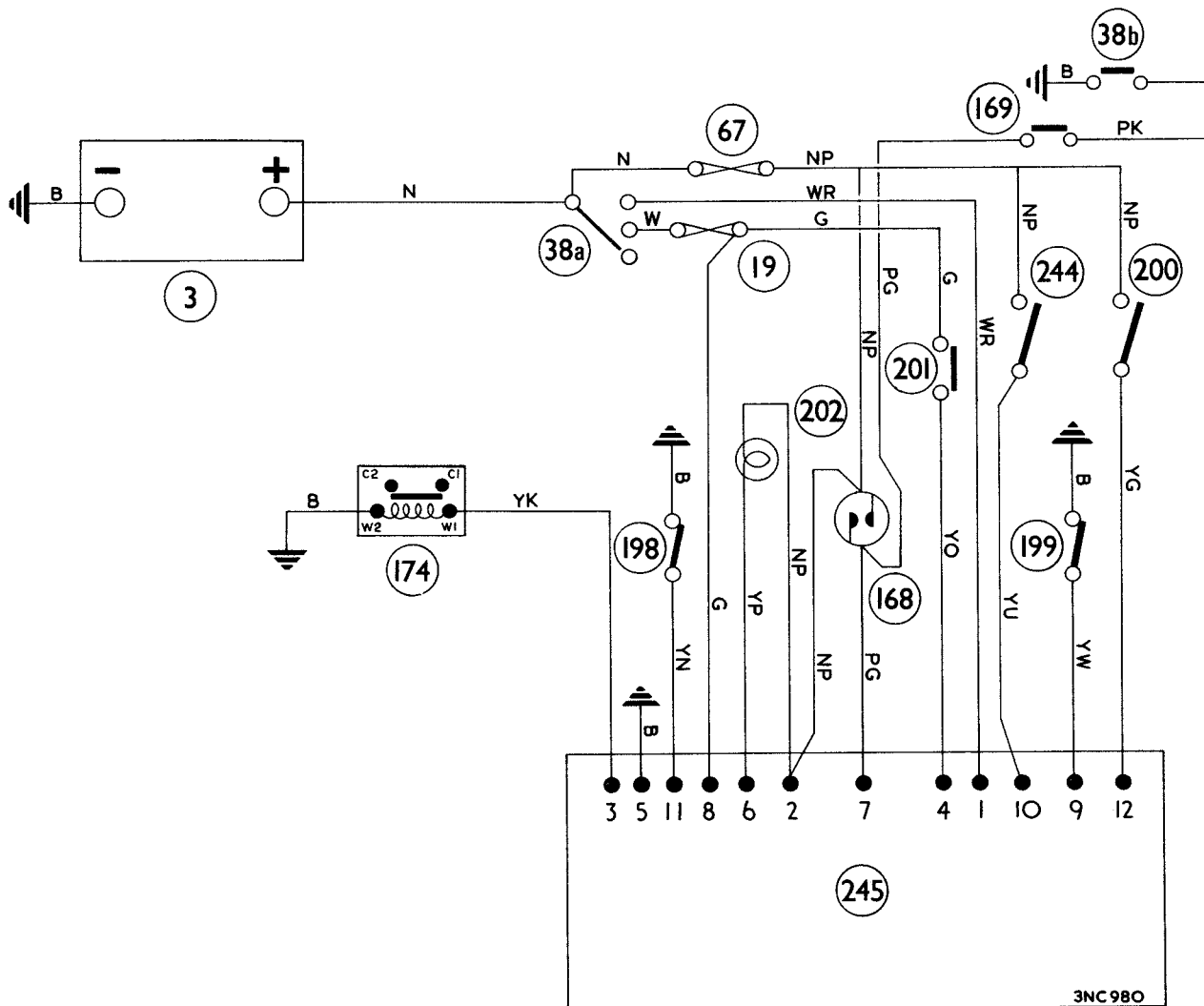

Fig. Nb.12

Sequential seat belt system circuit wiring diagram

- | | |
|---|--|
| 3. Battery. | 174. Starter motor relay. |
| 19. Fuse—35 amp. (connecting fuse box terminals 5 and 6). | 198. Driver's seat belt switch (normally closed). |
| 38a. Ignition/starter switch. | 199. Passenger's seat belt switch (normally closed). |
| 38b. Ignition key switch. | 200. Passenger's seat switch (normally open). |
| 67. Line fuse (500 milliamp.) | 201. Gearbox switch (closed in gear). |
| 168. Warning buzzer. | 202. 'Fasten belts' warning lamp. |
| 169. Warning buzzer door switch. | 244. Driver's seat switch (normally open). |
| | 245. System control unit. |

CABLE COLOUR CODE

| | | |
|-----------|------------|------------|
| B. Black. | N. Brown. | U. Blue. |
| G. Green. | O. Orange. | W. White. |
| K. Pink. | P. Purple. | Y. Yellow. |
| | R. Red. | |

When a cable has two colour code letters, the first denotes the main colour and the second denotes the tracer colour.

Section Nb.15

TESTING THE SEQUENTIAL SEAT BELT SYSTEM

Test conditions

1. Battery in good condition.
2. 500 milliamp. line fuse and the 35 amp. fuse connecting fusebox terminals '5' and '6' in good condition.
3. Gear lever in the neutral position.
4. Hand brake applied.
5. Detach the demister hose from the right-hand demister duct and the heater unit.

6. Compress the two retaining tags (see Fig. Nb.11) on the seat belt system control unit and disconnect the wiring plug from the control unit.

Control unit

Prove the control unit by substitution.

Switches and circuit wiring

Referring to Figs. Nb.11 and Nb.12 for circuit diagram and wiring harness plug pin identification numbers, carry out the following test procedure using a 12-volt 2.2-watt test lamp and a length of insulated cable.

APPENDIX

| Test | Procedure | | Circuit | Requirements | Remarks |
|---------------------------------|-------------------------------------|--------------------------------------|--|---|---|
| | Using test lamp to bridge plug pins | Using cable only to bridge plug pins | | | |
| 1. Supply from battery | 2 and 5 | — | Positive battery feed to earth | Test lamp ON | If the test lamp does not operate, the circuit is faulty. |
| 2. Driver's seat belt switch | 2 and 11 | — | Positive battery feed via belt switch to earth | (a) Test lamp ON— seat belt unfastened (b) Test lamp OFF— seat belt fastened | If the test lamp does not operate in (a) or lights in (b) either the seat belt switch or the circuit wiring is faulty. |
| 3. Driver's seat switch | 5 and 10 | — | Positive battery feed via driver's seat switch to earth | (c) Test lamp ON— driver seated (d) Test lamp OFF— driver unseated | If the test lamp does not operate in (c) or lights in (d), either the seat switch or the circuit wiring is faulty. |
| 4. Passenger's seat belt switch | 2 and 9 | — | Positive battery feed via belt switch to earth | (e) Test lamp ON— seat belt unfastened (f) Test lamp OFF— seat belt fastened | If the test lamp does not operate in (e) or lights in (f), either the seat belt switch or the circuit wiring is faulty. |
| 5. Passenger's seat switch | 5 and 12 | — | Positive battery feed via passenger's seat switch to earth | (g) Test lamp ON— passenger seated (h) Test lamp OFF— passenger unseated | If the test lamp does not operate in (g) or lights in (h), either the seat switch or the circuit wiring is faulty. |
| 6. Gearbox switch | 4 and 5 (ignition on) | — | Positive battery feed via ignition and gearbox switches to earth | Test lamp ON— gear engaged | If the test lamp does not operate when a gear is engaged, either the ignition or the gearbox switch, or the circuit wiring is faulty. If the test lamp lights when the gear lever is in neutral, the gearbox switch is faulty. |

APPENDIX

| Test | Procedure | | Circuit | Requirements | Remarks |
|--|-------------------------------------|--------------------------------------|---|--|---|
| | Using test lamp to bridge plug pins | Using cable only to bridge plug pins | | | |
| 7. Steering-column lock, ignition/starter switch | 1 and 5 | — | Positive battery feed via starter switch to earth | (j) Test lamp ON—switch in position 'III' (k) Test lamp OFF—switch in position 'O' or 'I' or 'II' | If the test lamp does not operate in (j), either the steering column lock, ignition/starter switch or the circuit wiring is faulty. If the test lamp lights in (k), the steering-column lock, ignition/starter switch is faulty. |
| 8. Starter relay | — | 2 and 3 | Positive battery feed via starter relay to earth | Starter motor operates | If the starter motor does not operate, either the starter relay or its circuit wiring or the starter or its circuit wiring is faulty. |
| 9. Seat belt warning lamp | — | 5 and 6 | Positive battery feed via warning lamp to earth | Warning lamp ON | If the warning lamp does not operate, either the warning lamp bulb or the circuit wiring is faulty. |
| 10. Warning buzzer | — | 5 and 7 | Positive battery feed via warning buzzer to earth | (l) Warning buzzer operates—ignition key removed (m) Warning buzzer does not operate—ignition key in switch, driver's door closed, and bridging cable disconnected from pins 5 and 7. | If the warning buzzer does not operate in (l), either the warning buzzer or the circuit wiring is faulty. If the warning buzzer operates in (m), either the driver's door switch or the circuit wiring between the warning buzzer and the door switch is faulty. |

APPENDIX

KEY TO THE WIRING DIAGRAMS

Use the one key to identify components on these wiring diagrams.

Refer to the appropriate wiring diagram, and disregard any additional numbered items appearing in the key and not on a particular diagram.

[NOTE:—The diagrams on the four following pages apply to the car models listed on page 249.]

1. Dynamo/alternator.
2. Control box.
3. Battery.
4. Starter solenoid.
5. Starter motor.
6. Lighting switch.
7. Headlamp dip switch.
8. Headlamp dip-beam.
9. Headlamp main beam.
10. Headlamp main-beam warning lamp.
11. R.H. parking lamp.
12. L.H. parking lamp.
13. Panel lamp switch.
14. Panel lamps.
15. Number-plate illumination lamp.
16. Stop lamp.
17. R.H. tail lamp.
18. Stop lamp switch.
19. Fuse unit.
20. Interior courtesy lamp.
21. Interior courtesy lamp door switch.
22. L.H. tail lamp.
23. Horns.
24. Horn-push.
25. Flasher unit.
26. Direction indicator switch.
27. Direction indicator warning lamp.
28. R.H. front flasher lamp.
29. L.H. front flasher lamp.
30. R.H. rear flasher lamp.
31. L.H. rear flasher lamp.
32. Heater or fresh-air motor switch.
33. Heater or fresh-air motor.
34. Fuel gauge.
35. Fuel gauge tank unit.
36. Windscreen wiper switch.
37. Windscreen wiper motor.
38. Ignition/starter switch.
39. Ignition coil.
40. Distributor.
41. Fuel pump.
43. Oil pressure gauge.
44. Ignition warning lamp.
45. Headlamp flasher switch.
46. Coolant temperature gauge.
49. Reverse lamp switch.
50. Reverse lamp.
57. Cigar-lighter—illuminated.
60. Radio.
64. Bi-metal instrument voltage stabilizer.
65. Luggage compartment lamp switch.
66. Luggage compartment lamp.
67. Line fuse.
77. Windscreen washer pump.
82. Switch illumination lamp.
94. Oil filter switch.
95. Tachometer.
105. Oil filter warning lamp.
118. Combined windscreen washer and wiper switch.
152. Hazard warning lamp.
153. Hazard warning switch.
154. Hazard warning flasher unit.
159. Brake pressure warning lamp and lamp test push.
160. Brake pressure failure switch.
168. Ignition key audible warning buzzer.
169. Ignition key audible warning door switch.
170. R.H. front side-marker lamp.
171. L.H. front side-marker lamp.
172. R.H. rear side-marker lamp.
173. L.H. rear side-marker lamp.
198. Driver's seat belt buckle switch.
199. Passenger's seat belt buckle switch.
200. Passenger seat switch.
201. Seat belt warning gearbox switch.
202. 'Fasten belts' warning light.
203. Line diode.
211. Heater control illumination bulb.

CABLE COLOUR CODE

| | | | |
|-----------|-------------------|------------|------------|
| N. Brown. | P. Purple. | W. White. | K. Pink. |
| U. Blue. | G. Green. | Y. Yellow. | O. Orange. |
| R. Red. | L.G. Light Green. | B. Black. | |

When a cable has two colour-code letters the first denotes the main colour and the second denotes the tracer colour

APPENDIX

Diagram 11
(Refer to page 373 for the key)

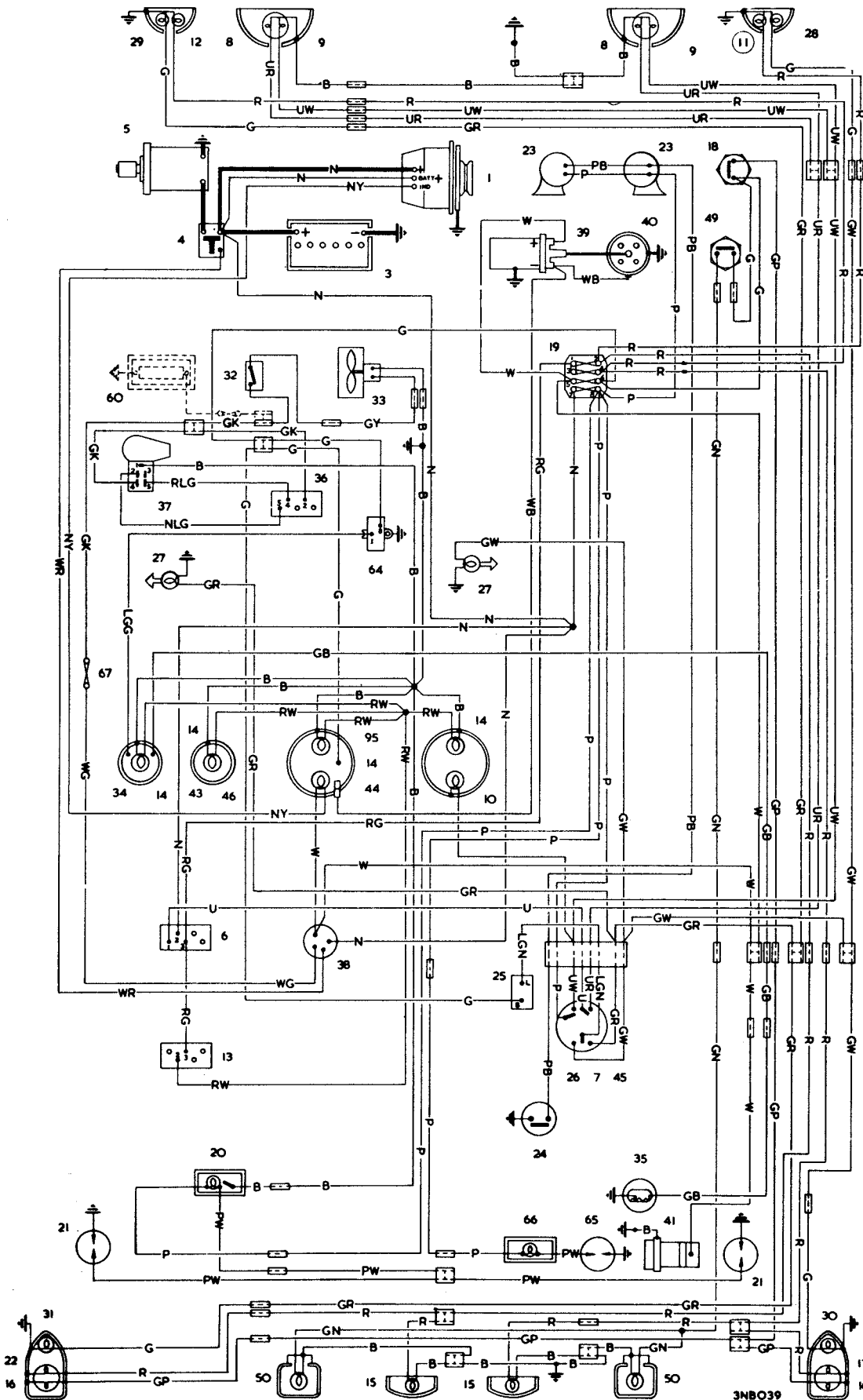

APPENDIX

Diagram 12
(Refer to page 373 for the key)

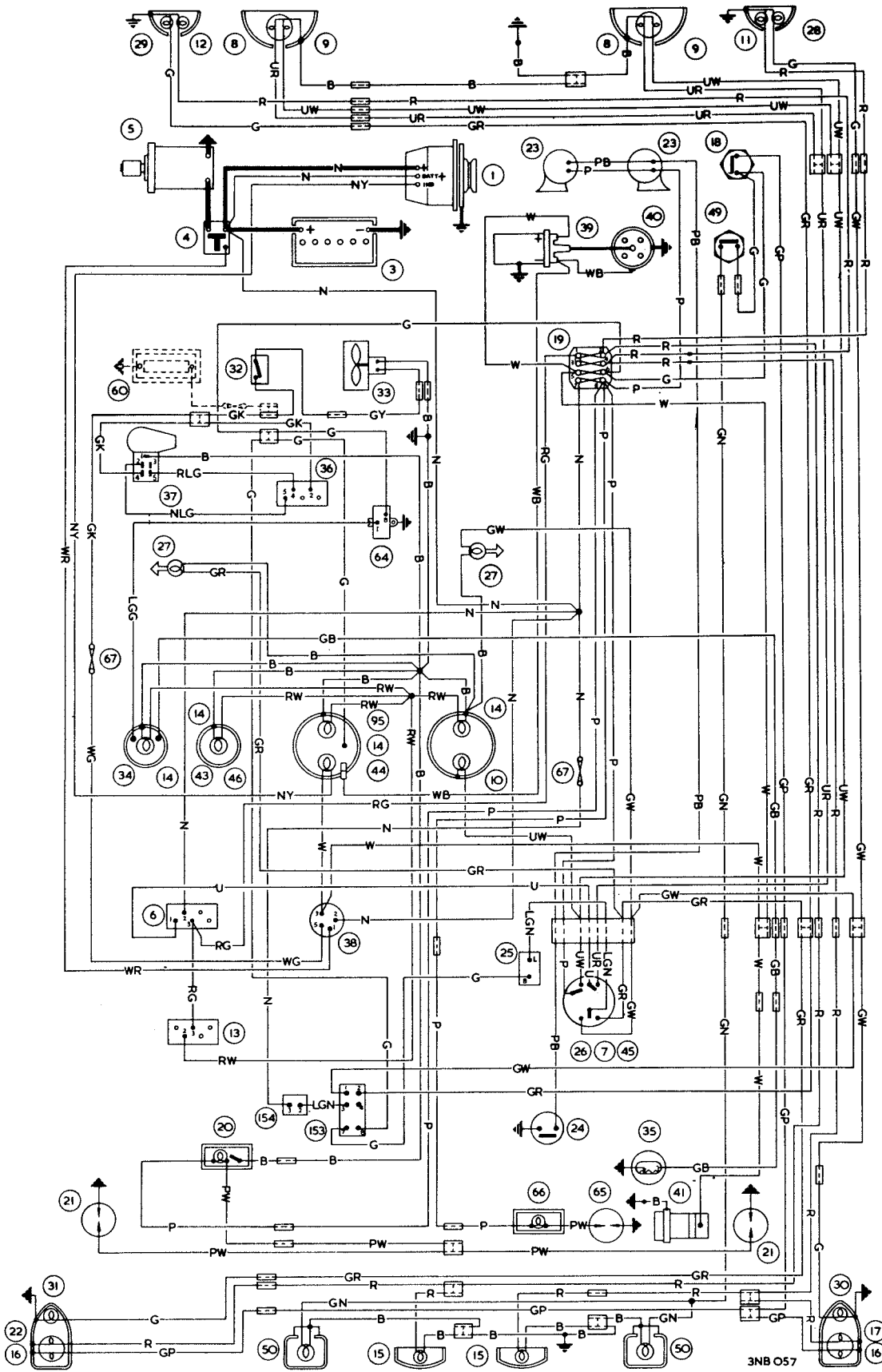

APPENDIX

Diagram 13 (Refer to page 373 for the key)

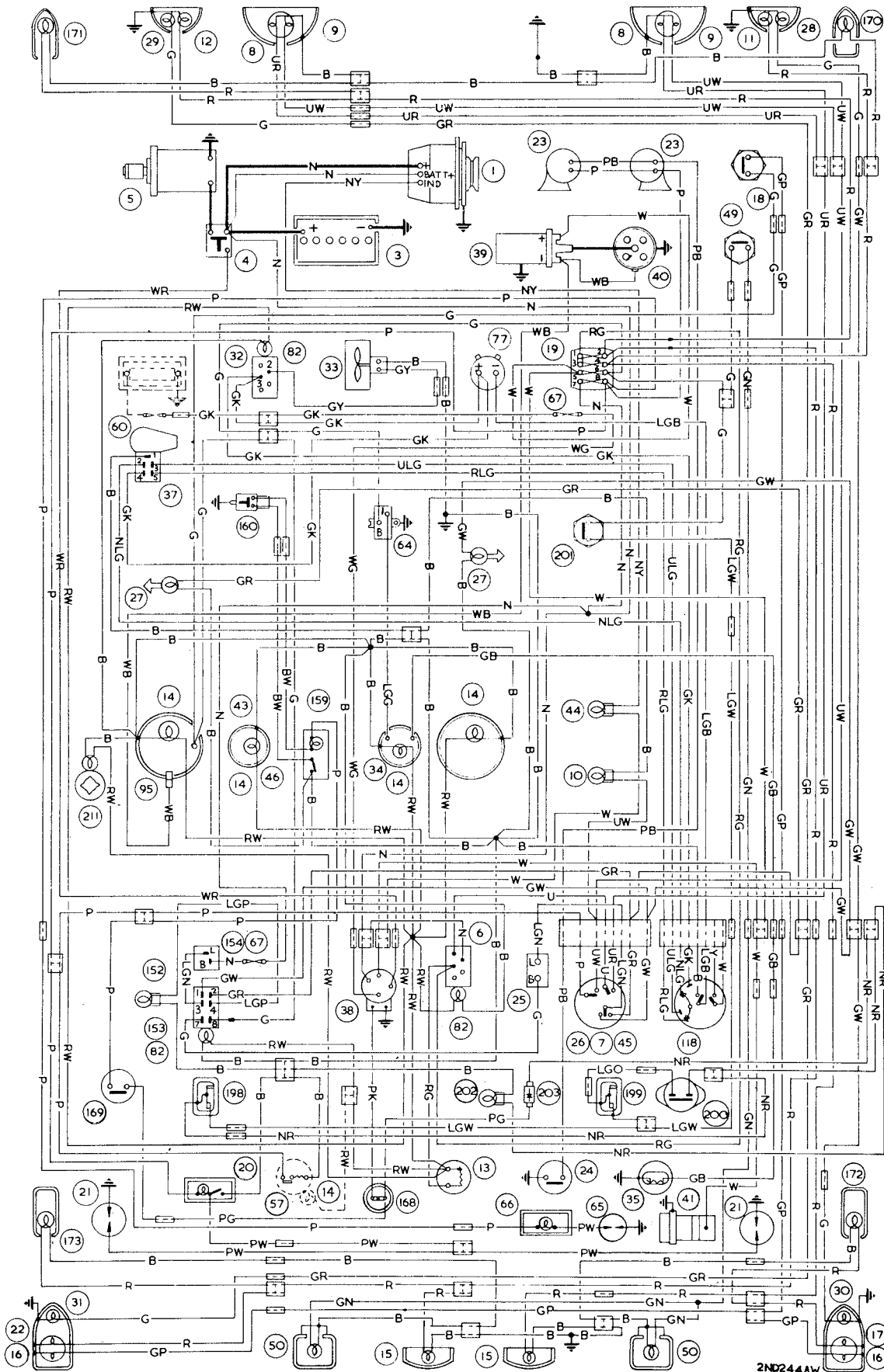

APPENDIX

Diagram 14
(Refer to page 373 for the key)

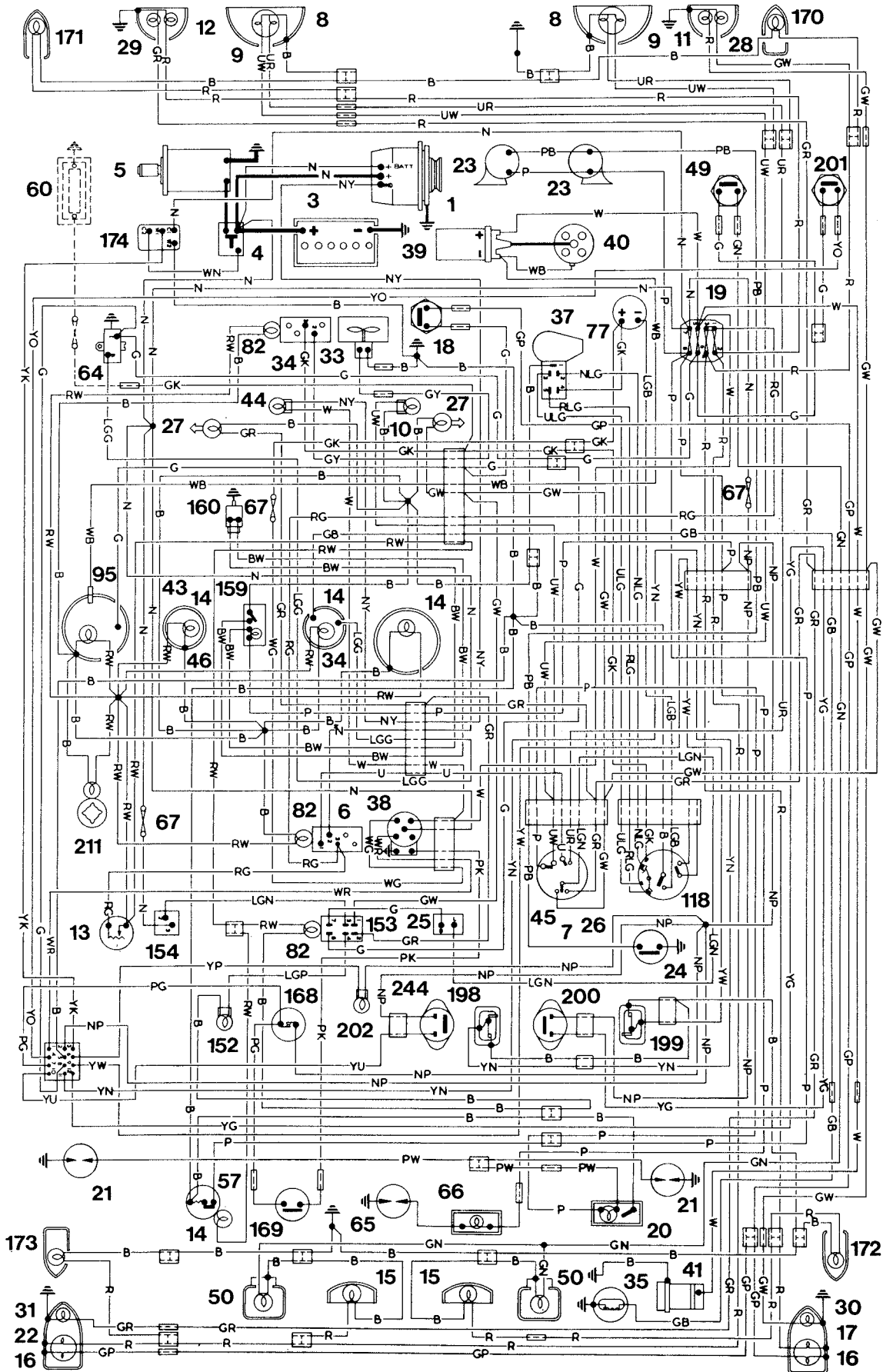

4NB 004 W

APPENDIX

Section Rb.6

THE FRONT BUMPER AND OVER-RIDERS

(Midget Mk. III from Car No. G-AN5-143355)

Removing

- (1) Remove the two nuts to release the front bumper assembly from the mounting brackets.
- (2) Remove the nuts from the dome headed bolts, withdraw the bolts and detach the support spring from the main spring, noting the small spacers fitted between the main spring and the bumper bar.
- (3) Remove the small bolts securing the centre and each end of the bumper bar to the main spring.
- (4) Remove each over-rider assembly retaining bolt and detach the over-riders, support castings, bumper bar, main spring, and reinforcement bracket, noting the large spacer fitted between the bumper bar and the main spring.
- (5) Remove the nuts, bolts, and spacers to release the number-plate from the bumper.
- (6) To dismantle the over-rider assembly proceed as follows:
 - (a) Mark the over-rider clamping bracket and mounting bracket at the top to assist re-assembly.
 - (b) Remove the clamping bracket securing screws and remove the clamping bracket.
 - (c) Slide the mounting bracket from the over-rider.

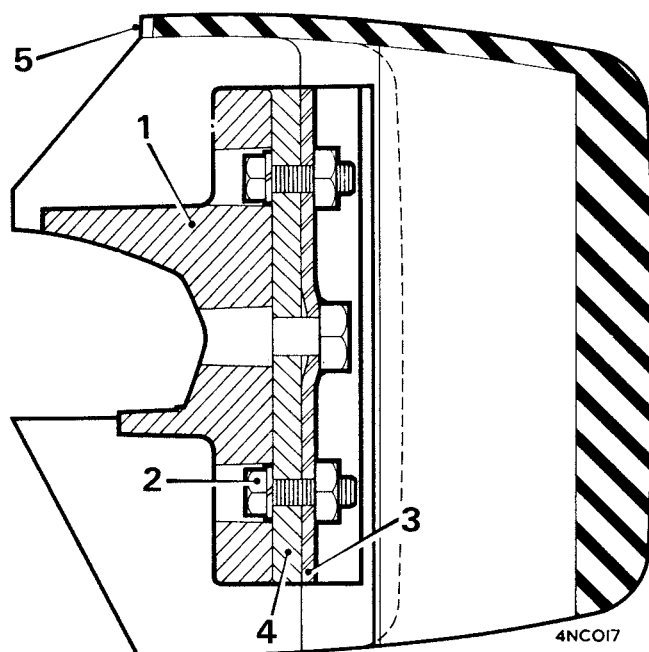

Fig. Rb.4

*The over-rider assembly and support casting
(Midget Mk. III from Car. No. G-AN5-143355)*

- | | |
|---------------------------------------|----------------------|
| 1. Support casting. | 3. Clamping bracket. |
| 2. Clamping bracket securing bolt. | 4. Mounting bracket. |
| | 5. Over-rider. |

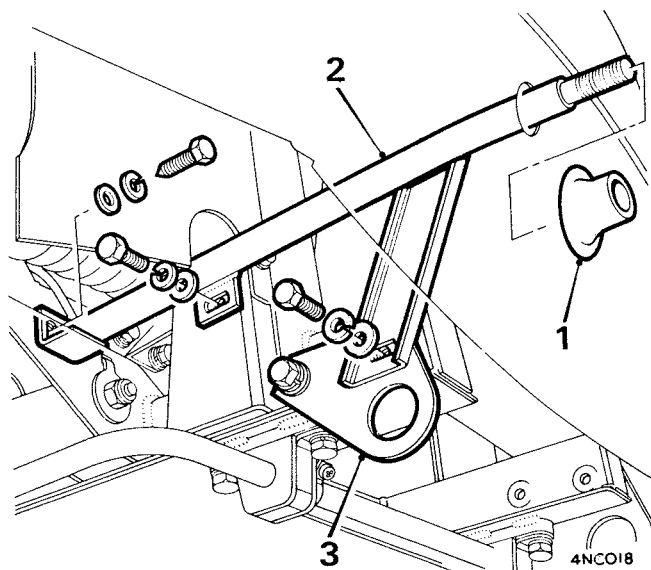

Fig. Rb.5

*The front bumper mounting bracket
(Midget Mk. III from Car No. G-AN5-143355)*

- | | |
|----------------|----------------------------------|
| 1. Grommet. | 3. Front bumper mounting bracket |
| 2. Towing eye. | |

Refitting

- (7) Reverse the procedure in 1 to 6, referring to Fig. Rb.3 and noting:
 - (a) Ensure that the clamping bracket is correctly fitted.
 - (b) The over-rider assemblies are handed.
 - (c) The fitted position of the over-rider assembly retaining bolt is at an angle; take care not to damage the thread.
 - (d) Ensure that the bumper spacers and number-plate spacers are correctly fitted, noting that the flat face of the bumper spacers are lowermost.

Section Rb.7

THE FRONT BUMPER MOUNTING BRACKET

(Midget Mk. III from Car No. G-AN5-143355)

Removing

- (1) Remove the two nuts securing the bumper assembly to release the front bumper assembly.
- (2) Remove the grommet from the front mounting bracket.
- (3) Slacken the towing eye rearmost securing bolt.
- (4) Remove the three bolts securing the mounting bracket.
- (5) Swing the long support of the mounting bracket towards the road wheel and manoeuvre the mounting bracket down and then rearwards.

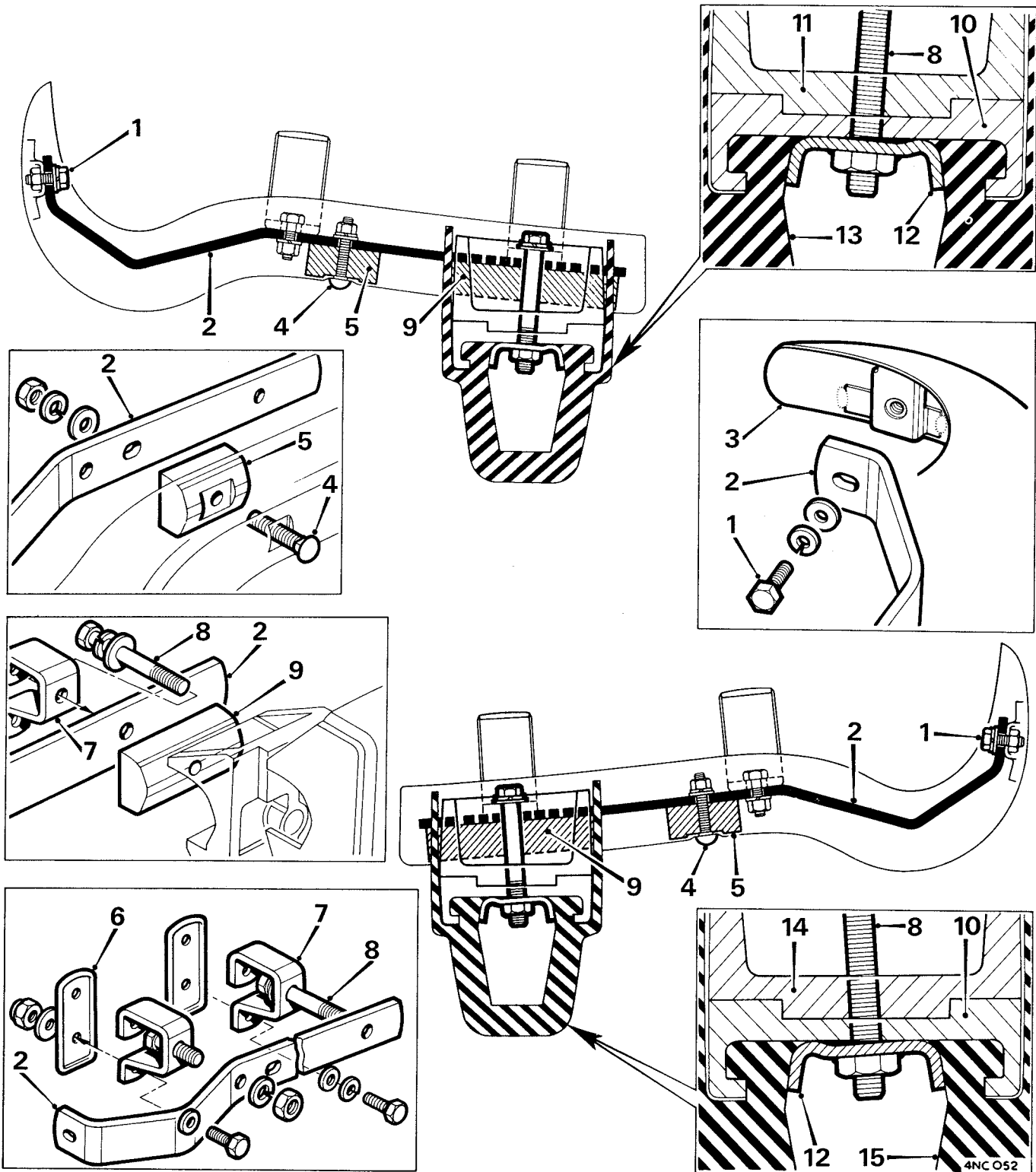

Fig. Rb.6

The rear bumper assembly (Midget Mk. III from Car No. G-AN5-143355)

- | | |
|---------------------------------------|--|
| 1. Bumper bar securing bolt. | 9. Large spacer. |
| 2. Main spring. | 10. Over-rider mounting bracket. |
| 3. Bumper bar. | 11. Left-hand over-rider support casting. |
| 4. Dome head bolt. | 12. Over-rider clamping bracket. |
| 5. Small spacer. | 13. Left-hand over-rider. |
| 6. Gasket. | 14. Right-hand over-rider support casting. |
| 7. Mounting bracket. | 15. Right-hand over-rider. |
| 8. Over-rider assembly securing bolt. | |

APPENDIX

Refitting

- (6) Reverse the procedure in 1 to 5, noting:
 - (a) The towing eye bracket is fitted between the mounting bracket support and the longitudinal member.
 - (b) Fit the mounting bracket securing bolts finger tight, tightening them only when the bumper assembly is secured to the brackets.

Section Rb.8

THE REAR BUMPER AND OVER-RIDERS

(Midget Mk. III from Car No. G-AN5-143355)

Removing

- (1) Remove the mounting bracket securing nuts and bolts to release one half of the rear bumper assembly from the body together with the gaskets.
- (2) Remove the nut and bolt to release the outer mounting bracket from the main spring.
- (3) Unscrew the nut and remove the dome headed bolt, noting the small spacer fitted between the bumper bar and the main spring. Remove the small bolt securing the end of the bumper to the main spring.

- (4) Remove the over-rider assembly retaining bolt to remove the over-rider assembly, support casting and inner mounting bracket from the bumper bar and main spring, noting the large spacer fitted between the bumper bar and main spring.
- (5) To dismantle the over-rider assembly proceed as follows:
 - (a) Mark the clamping bracket and the mounting bracket at the top to assist reassembling.
 - (b) Remove the clamping bracket securing screws and remove the clamping bracket.
 - (c) Slide the mounting bracket from the over-rider.
- (6) Repeat procedures 1 to 5 for the other rear bumper assembly.

Refitting

- (7) Reverse the procedure in 1 to 6, referring to Fig. Rb.6 and noting the following:
 - (a) Ensure that the clamping bracket is correctly fitted to the over-rider.
 - (b) The over-rider assemblies are handed.
 - (c) The fitted position of the over-rider assembly retaining bolt is at an angle; take care not to damage the thread.

APPENDIX

R.H.D. and L.H.D. except North America—continued

| After Sales | A | B | C | ACTION ● OPERATION X |
|----------------|---|---|---|---|
| X | X | X | X | Check visually for external cuts in tyre fabric |
| X | X | X | X | Check visually for external exposure of ply or cord |
| X | X | X | X | Check visually for external lumps or bulges |
| X | X | X | X | Check/adjust tyre pressures |
| ● | ● | ● | ● | Refit spare wheel. Drive car off lift |
| X | X | X | X | Check/adjust headlamp alignment |
| X | X | X | | Check/adjust front wheel alignment |
| X | X | X | | Carry out road or roller test and check function of all instrumentation |
| X | X | X | X | Report any additional work required |
| X | X | X | X | Ensure cleanliness of controls, door handles, steering-wheel, etc. |
| ● | ● | ● | ● | Remove seat cover |

This Maintenance Summary was produced from Leycare Supplementary Job Sheet AKD 8495 (1st Edition). Job sheets used by British Leyland Distributors and Dealers operating Leycare Service are updated as modifications affecting routine maintenance are introduced, and the content of this maintenance summary may differ from that currently used by Leycare Service operatives.

APPENDIX

North America—continued

SAFETY

- Check/adjust front wheel alignment
- Check visually hydraulic pipes, unions for chafing, leaks and corrosion
- Check/adjust hand brake operation
- Inspect brake pads for wear and discs for condition
- Inspect brake linings and pads for wear, drums and discs for condition
- Check/adjust headlights
- Check tyres visually and report depth of tread, cuts in fabric, exposure of ply or cord structure, lumps or bulges
- Check operation of all door locks and window controls.....
- Check condition, operation and security of seats and seat belts/interlock
- Check wiper blades for condition

| | A | B |
|--|---|---|
| | | X |
| | | X |
| | X | X |
| | X | |
| | | X |
| | X | X |
| | X | X |
| | | X |
| | | X |
| | | X |
| | | X |
| | X | X |

ROAD TEST

- Ensure that operation of vehicle is satisfactory and report all items requiring attention.....

***24,000 miles or 24-month intervals**

- *†Renew all drive belts
- *†Check air pump (correct or renew if necessary)
- *†Renew adsorption canister
- *†Renew distributor cap and wires

***36,000 miles or 36-month intervals**

- *Renew all hydraulic brake seals

The maintenance summary on this and the preceding pages is the minimum service required to maintain your vehicle under normal driving conditions. For other than normal driving conditions and those caused by seasonal changes, we recommend that you consult your Dealer.

APPENDIX

R.H.D. and L.H.D. EXCEPT NORTH AMERICA

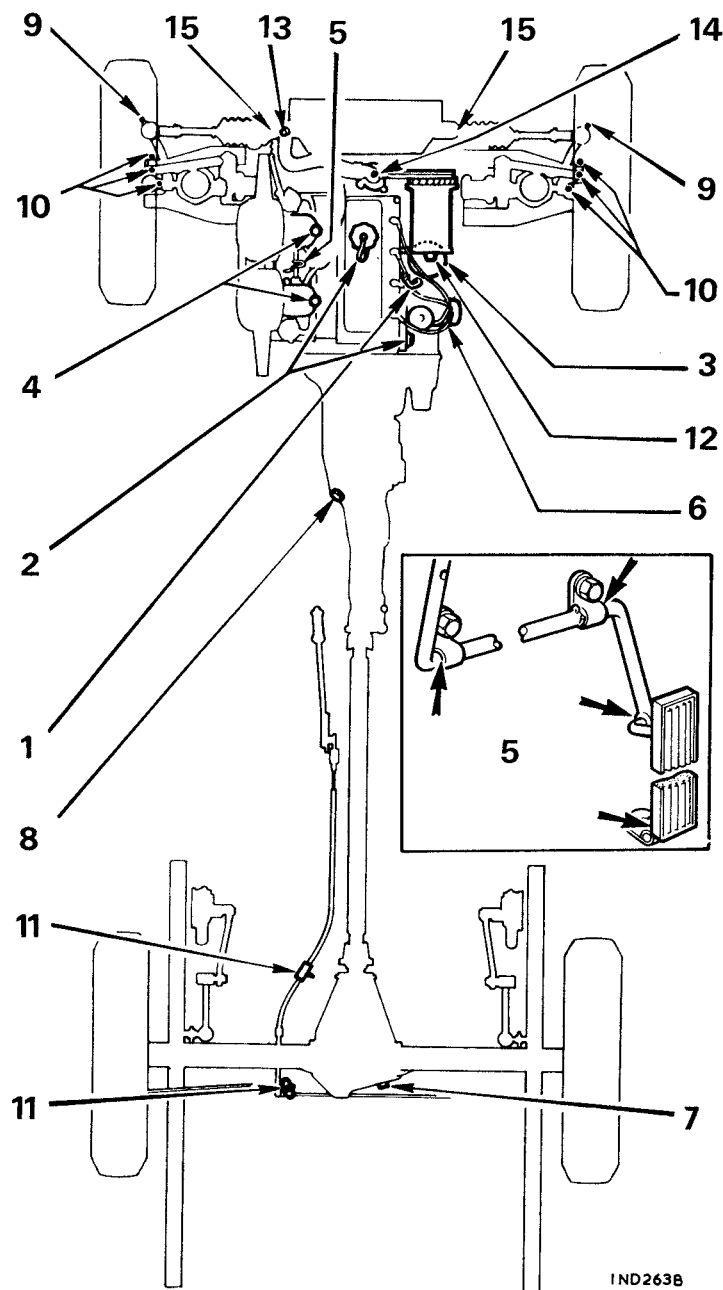

NOTE.—Ensure that the vehicle is standing on a level surface when checking the oil levels.

Weekly

(1) ENGINE. Check oil level and top up if necessary.

Every 6,000 miles (10 000 km) or 6 months

- (2) ENGINE. Drain and refill with new oil.
- (3) ENGINE OIL FILTER. Remove disposable cartridge, fit new. Early cars: Drain filter, wash filter bowl in fuel and fit new element.
- (4) CARBURETTERS. Top up carburetter piston dampers.
- (5) ACCELERATOR. Lubricate accelerator control linkage, cable and pedal fulcrum.
- (6) DISTRIBUTOR. Lubricate all parts as necessary.
- (7) REAR AXLE. Check oil level, and top up if necessary.
- (8) GEARBOX. Check oil level and top up if necessary.
- (9) STEERING TIE-ROD BALL JOINT (2 nipples)
- (10) FRONT SUSPENSION (6 nipples)
- (11) HAND BRAKE CABLE (1 nipple) and mechanical linkage

Give three or four strokes with a grease gun.

(12) DYNAMO (*Early cars only*). Add a few drops of oil through the oil hole in the commutator end bearing.

Every 12,000 miles (20 000 km) or 12 months

- (13) STEERING RACK (*Early cars*—with an oil nipple fitted). Give 10 strokes with an oil gun.
- (14) WATER PUMP (*Early cars only*). Remove the plug and add grease; do not overgrease.

Every 30,000 miles (50 000 km) or 36 months

- (15) STEERING RACK (*Later cars*—from Car No. G-AN5-114643). Lubricate steering rack.—It is advisable that this work is entrusted to your Distributor or Dealer.

Optional lubrication at 3,000 miles (5000 km) or 3 months

- (1) ENGINE. Check oil level and top up if necessary.

APPENDIX

NORTH AMERICA

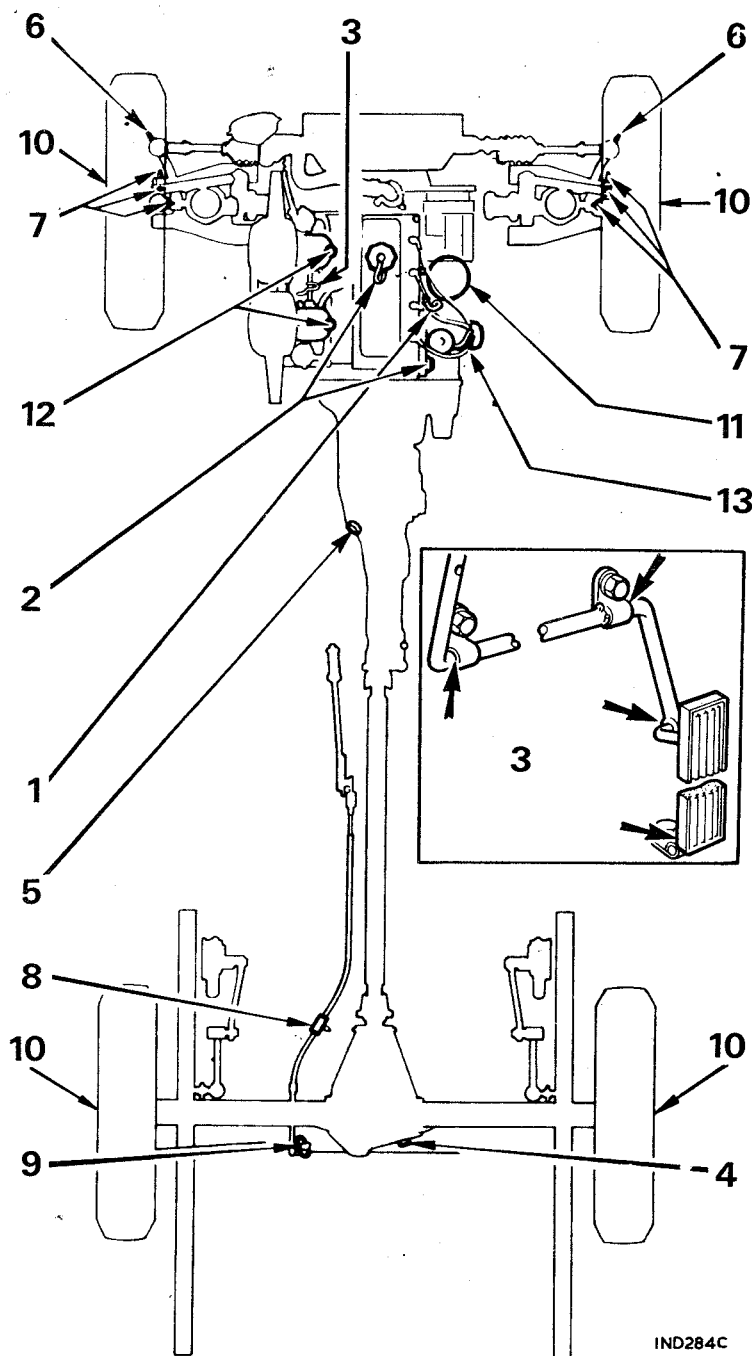

IND284C

NOTE.—Ensure that the vehicle is standing on a level surface when checking the oil levels.

Weekly

(1) **ENGINE.** Check oil level, and top up if necessary.

Lubrication service every 3,000 miles or 3 months

- (2) **ENGINE.** Drain and refill with new oil.
- (3) **THROTTLE AND CHOKE.** Lubricate throttle and choke control linkages, cables, and accelerator pedal fulcrum.
- (4) **REAR AXLE.** Check oil level, and top up if necessary.
- (5) **GEARBOX.** Check oil level, and top up if necessary.
- (6) **STEERING TIE-ROD BALL JOINT** (2 nipples)
- (7) **FRONT SUSPENSION** (6 nipples)
- (8) **HAND BRAKE CABLE** (1 nipple)
- (9) **HAND BRAKE COMPENSATING LEVER** (1 nipple)

} Give three or four strokes with a grease gun

(10) **WHEELS AND HUBS.** Lubricate wire wheel and hub splines.

LOCKS, HINGES AND LINKAGES. Lubricate all door, bonnet and boot locks and hinges; and the hand brake mechanical linkage.

FRICTION POINTS. Spray lubricant on all friction points.

'A' service every 6,000 miles or 6 months; AND 'B' service every 12,000 miles or 12 months

- (11) **ENGINE OIL FILTER.** Remove disposable cartridge, fit new.
- (12) **CARBURETTERS.** Top up carburetter piston dampers.
- (13) **DISTRIBUTOR.** Lubricate all parts as necessary.