

SECTION M

THE BRAKING SYSTEM

	<i>Section</i>
Adjustment	M.2
Bleeding the system	M.4
Brake pedal	
Adjustment	M.3
Removing and refitting	M.6
Brake-shoe relining	M.11
Flexible hoses	M.7
Front brake assemblies	
Disc brakes	M.9
Drum brakes	M.8
Maintenance	M.1
Master cylinder	M.5
Rear brake assemblies	M.10

THE FRONT BRAKE COMPONENTS

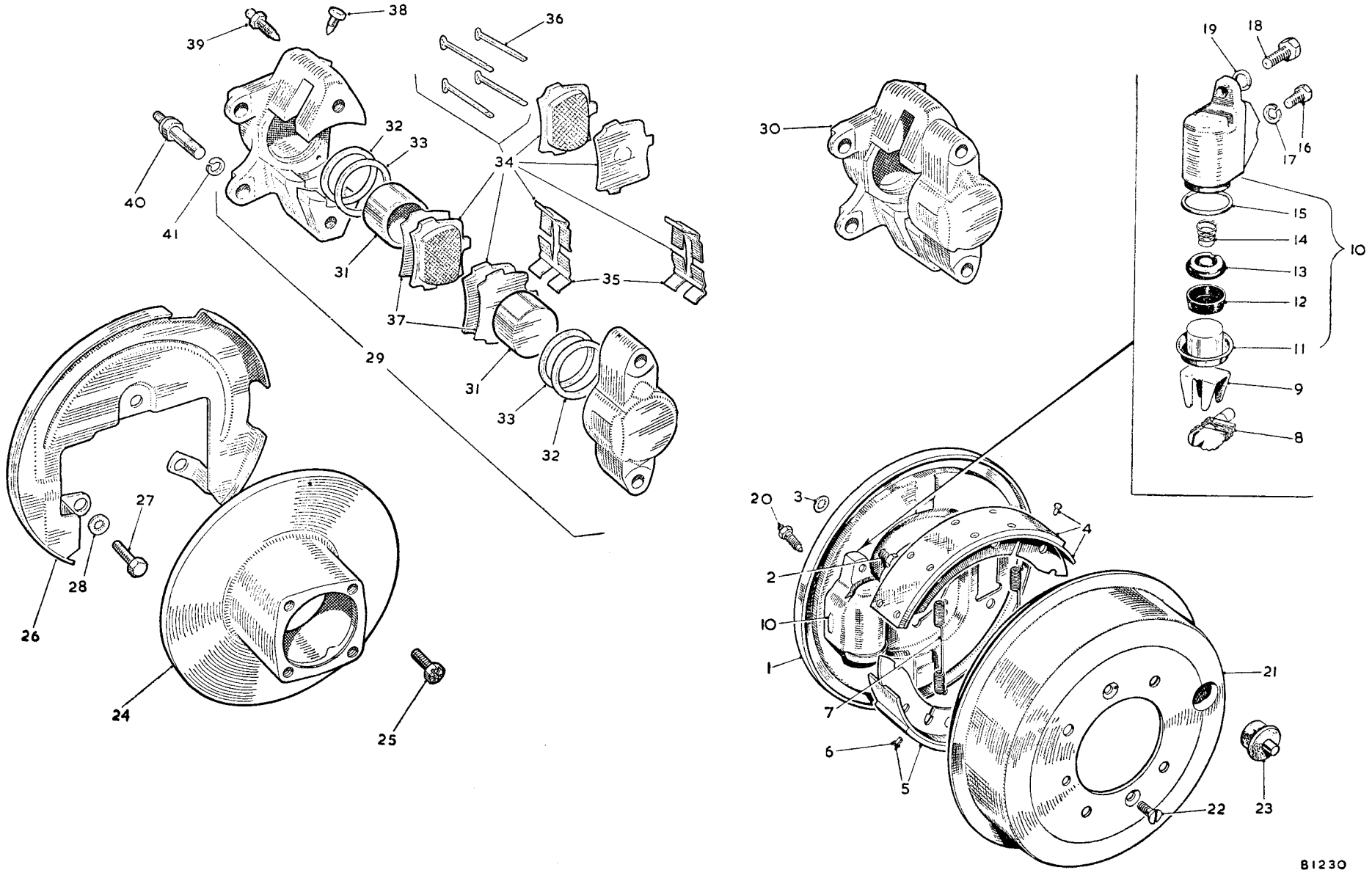

KEY TO THE FRONT BRAKE COMPONENTS

<i>No.</i>	<i>Description</i>		<i>No.</i>	<i>Description</i>		<i>No.</i>	<i>Description</i>
1.	Brake-plate.	}	15.	Sealing ring.	}	29.	Calliper unit assembly—L.H.
2.	Set screw.		16.	Set screw (small).		30.	Calliper—L.H.
3.	Shakeproof washer		17.	Spring washer.		31.	Piston.
4.	Brake-shoe assembly.		18.	Set screw (large).		32.	Inner seal.
5.	Liner with rivets.		19.	Spring washer.		33.	Dust seal and retainer.
6.	Rivet.		20.	Bleeder screw.		34.	Pad assembly.
7.	Pull-off spring.		21.	Brake-drum.		35.	Pad retaining spring.
8.	Micram adjuster.		22.	Set screw.		36.	Split cotter pin.
9.	Mask.		23.	Plug.		37.	Pad shim.
10.	Wheel cylinder assembly.		24.	Brake disc.		38.	Plug.
11.	Piston with dust cover.		25.	Set screw.	39.	Bleed screw.	
12.	Cup.		26.	Dust cover.	40.	Calliper mounting bolt.	
13.	Cup filler.		27.	Set screw.	41.	Spring washer.	
14.	Spring.		28.	Shakeproof washer.			

THE REAR BRAKE COMPONENTS

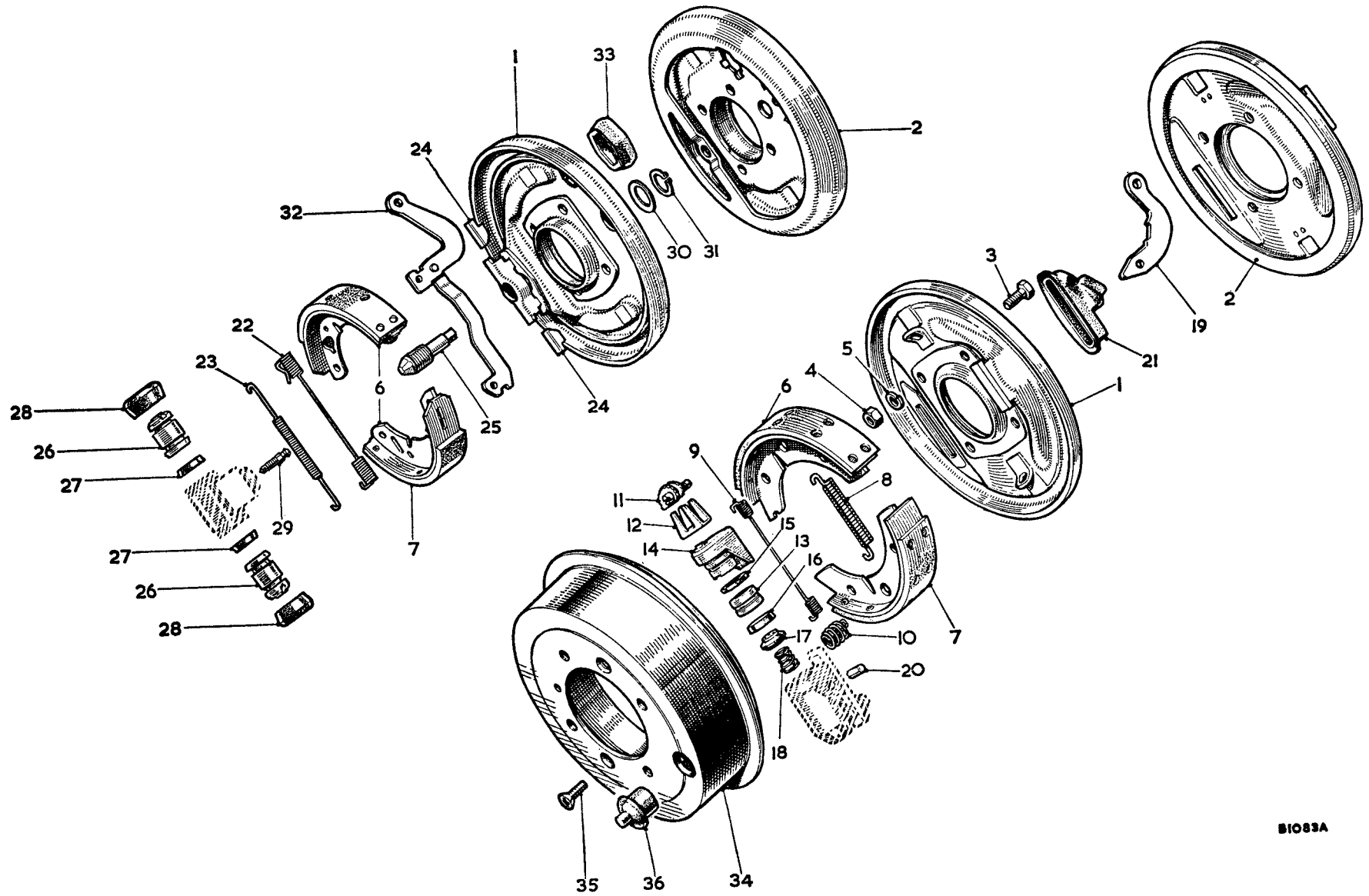

B1083A

KEY TO THE REAR BRAKE COMPONENTS

<i>No.</i>	<i>Description</i>	<i>No.</i>	<i>Description</i>	<i>No.</i>	<i>Description</i>
1.	Brake-plate—R.H.	13.	Piston.	25.	Wedge.
2.	Brake-plate—L.H.	14.	Piston with dust cover.	26.	Piston.
3.	Set screw.	15.	Seal.	27.	Seal.
4.	Nut.	16.	Cup.	28.	Boot.
5.	Spring washer.	17.	Cup filler.	29.	Bleeder screw.
6.	Brake-shoe assembly.	18.	Spring.	30.	Belleville washer.
7.	Liner with rivets.	19.	Hand brake lever.	31.	Circlip.
8.	Shoe return spring (abutment end).	20.	Pivot pin.	32.	Hand brake lever.
9.	Shoe return spring (cylinder end).	21.	Boot.	33.	Boot.
10.	Steady spring.	22.	Shoe return spring (cylinder end).	34.	Brake-drum.
11.	Adjuster assembly.	23.	Shoe return spring (adjuster end).	35.	Set screw.
12.	Mask adjuster.	24.	Tappet.	36.	Plug.

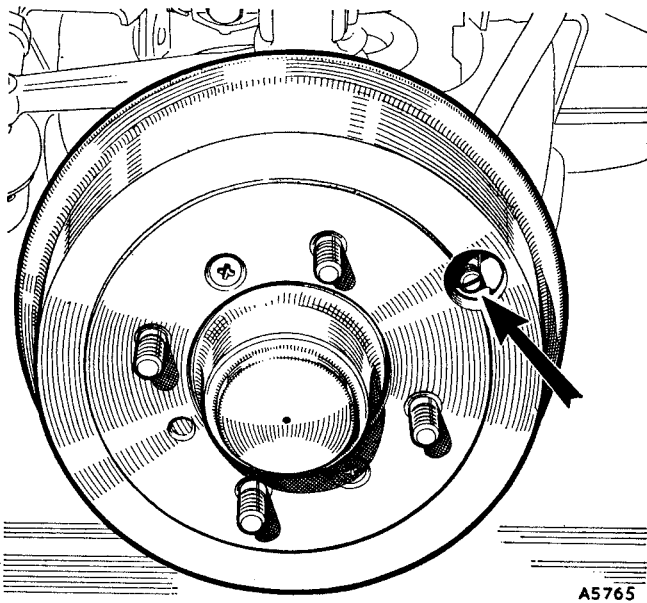

Fig. M.1

Showing a front brake-drum with one of the brake-shoe adjusters

Section M.1

MAINTENANCE

General

The fluid in the master cylinder reservoir must be maintained at a level $\frac{1}{4}$ in. (6.5 mm.) below the bottom of the filler neck. The necessity of frequent topping up is an indication of a leak in the system which must be traced and rectified.

IMPORTANT.—Serious consequences may result from the use of incorrect fluids, use only the recommended fluid given in 'GENERAL DATA'.

Excessive travel of the brake pedal is an indication that the brake-shoes require adjusting. For brake adjustments see Section M.2.

Disc brakes

In order to maintain peak braking efficiency and at the same time obtain maximum life from the front brake friction pads, the pads should be examined periodically, and if one pad is worn more than the other their operating positions should be changed over.

Lubrication

A lubricating nipple is provided on the hand brake balance lever, and on the hand brake cable. Both nipples should be charged with a recommended lubricant at the periods specified in the vehicle Driver's Handbook.

Preventive Maintenance

To safeguard against the possible effects of wear, or deterioration, it is recommended that:

- (1) Disc brake pad, drum brake linings, hoses, and pipes should be examined at intervals no greater than those laid down in the Passport to Service.

M.6

- (2) Brake fluid should be changed completely every 18 months or 24,000 miles (40,000 km.) whichever is the sooner.
- (3) All fluid seals in the hydraulic system and all flexible hoses should be examined and renewed if necessary every 3 years or 40,000 miles (65,000 km.) whichever is the sooner. At the same time the working surface of the pistons and of the bores of the master cylinder, wheel cylinders, and other slave cylinders should be examined and new parts fitted where necessary.

Care must be taken always to observe the following points:

- (a) At all times use the recommended brake fluid.
- (b) Never leave fluid in unsealed containers. It absorbs moisture quickly and this can be dangerous.
- (c) Fluid drained from the system or used for bleeding is best discarded.
- (d) The necessity for absolute cleanliness throughout cannot be over-emphasized.

Section M.2

ADJUSTMENT

Front

Drum brakes

- (1) Apply the hand brake, and jack up the car until the wheel is free to rotate.
- (2) Remove the wheel disc, and the rubber plug in the drum.
- (3) Rotate the wheel until one of the adjusters is accessible through the hole in the drum (see Fig. M.1).
- (4) Using a screwdriver, turn the adjuster in a clockwise direction until the brake-shoe contacts the drum.
- (5) Turn the adjuster back just sufficiently for the wheel to rotate without the brake-shoe rubbing the drum.

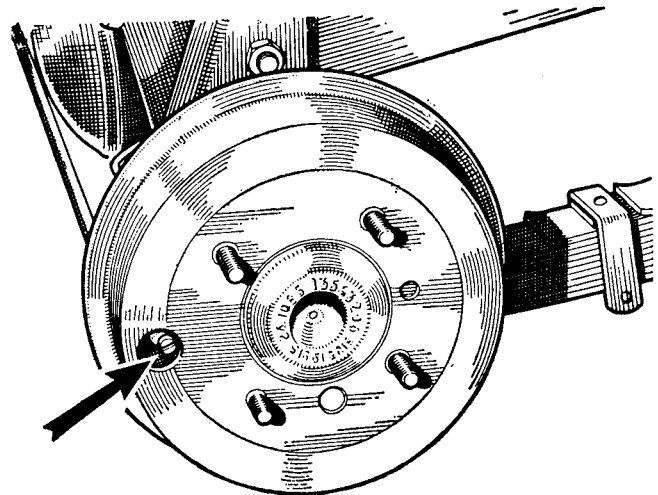

Fig. M.2

Showing rear brake-shoe adjuster

Sprite and Midget. Issue 5. 4780

- (6) Turn the wheel until the other adjuster is accessible through the hole in the drum and repeat the operations in (4) and (5).
- (7) Spin the wheel and apply the brakes hard, then recheck the adjustment.
- (8) Refit the rubber plug and wheel disc.
- (9) Repeat the operations in (1) to (8) for the other front brake.

Disc brakes

- (10) Wear on the friction pads is automatically compensated during braking and therefore no manual adjustment is provided. If both friction pads are not worn the same amount change their operating positions (see Section M.1) or if the pads are worn down to the minimum thickness of $\frac{1}{8}$ in. (1.59 mm.) renew the pads (see Section M.9).

Rear

Early cars

- (11) Block both front wheels, fully release the hand brake, and jack up the car until the wheel is free to rotate.
- (12) Remove the wheel disc, and the rubber plug in the brake-drum.
- (13) Rotate the wheel until the adjuster is accessible through the hole in the drum.
- (14) Using a screwdriver turn the adjusters in a clockwise direction until the shoes lock the brake-drum.
- (15) Turn the adjuster back just sufficiently for the wheel to rotate without the brake-shoes rubbing the drum.
- (16) Repeat the operations in (11) to (15) for the other rear brake.

Later cars

- (17) Block both front wheels, fully release the hand brake, and jack up the car until the wheel is free to rotate.
- (18) Turn the adjuster, located on the back of the brake

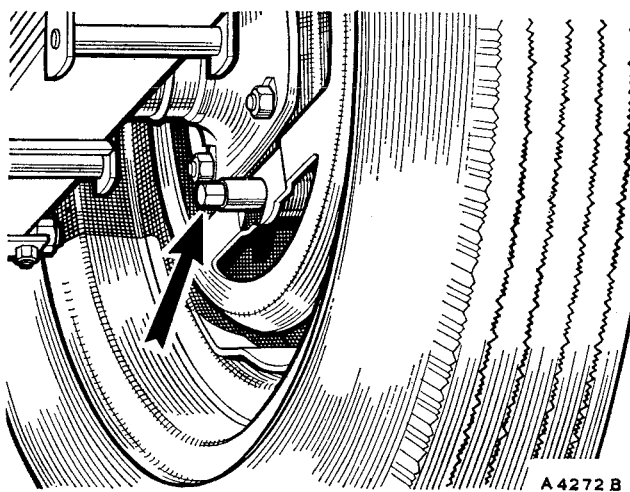

Fig. M.3

One square-headed brake adjusting bolt is provided on each rear brake-plate

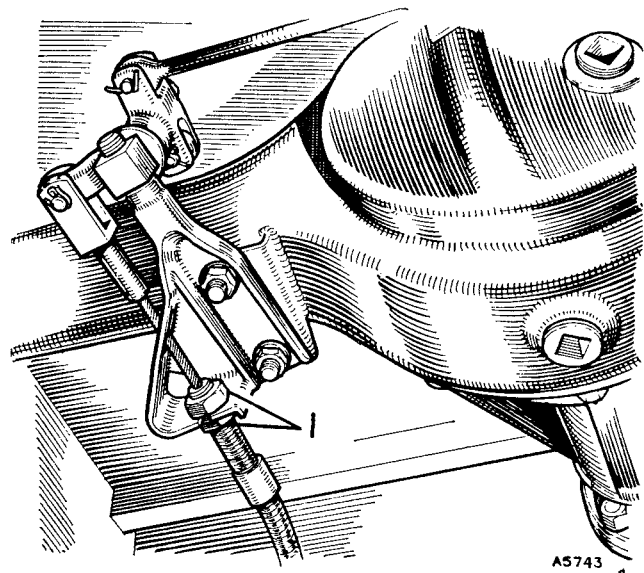

Fig. M.4

Shows location of hand brake cable adjuster (1) on the rear axle

- backplate, in a clockwise direction until the shoes lock the brake-drum.
- (19) Turn the adjuster back just sufficiently for the wheel to rotate without the brake-shoes rubbing.
- (20) Repeat the operations in (17) to (19) for the other rear brake.

Hand brake

- (21) Adjust the rear brake-shoes as detailed in (11) to (16) (early cars) or (17) to (20) (later cars).
- (22) Block both front wheels and jack up the rear of the car.
- (23) Apply the hand brake so that the pawl engages with the third notch on the ratchet.
- (24) Adjust the hand brake cable, with the sleeve nut (Fig. M.4), until it is just possible to rotate each wheel by heavy hand pressure. Both wheels must offer equal resistance in order to get full braking power.
- (25) Release the hand brake and check that both wheels rotate freely.

Section M.3

BRAKE PEDAL ADJUSTMENT

The correct amount of free movement of the master cylinder push-rod when the brake pedal is depressed is set during the vehicle assembly, and should only require adjustment if components have been renewed.

- (1) Slacken the adjuster nut on the master cylinder push-rod.
- (2) Set the length of the push-rod to give a free movement of the pedal pad of approximately $\frac{1}{2}$ in. (4 mm.) before the master cylinder piston begins to

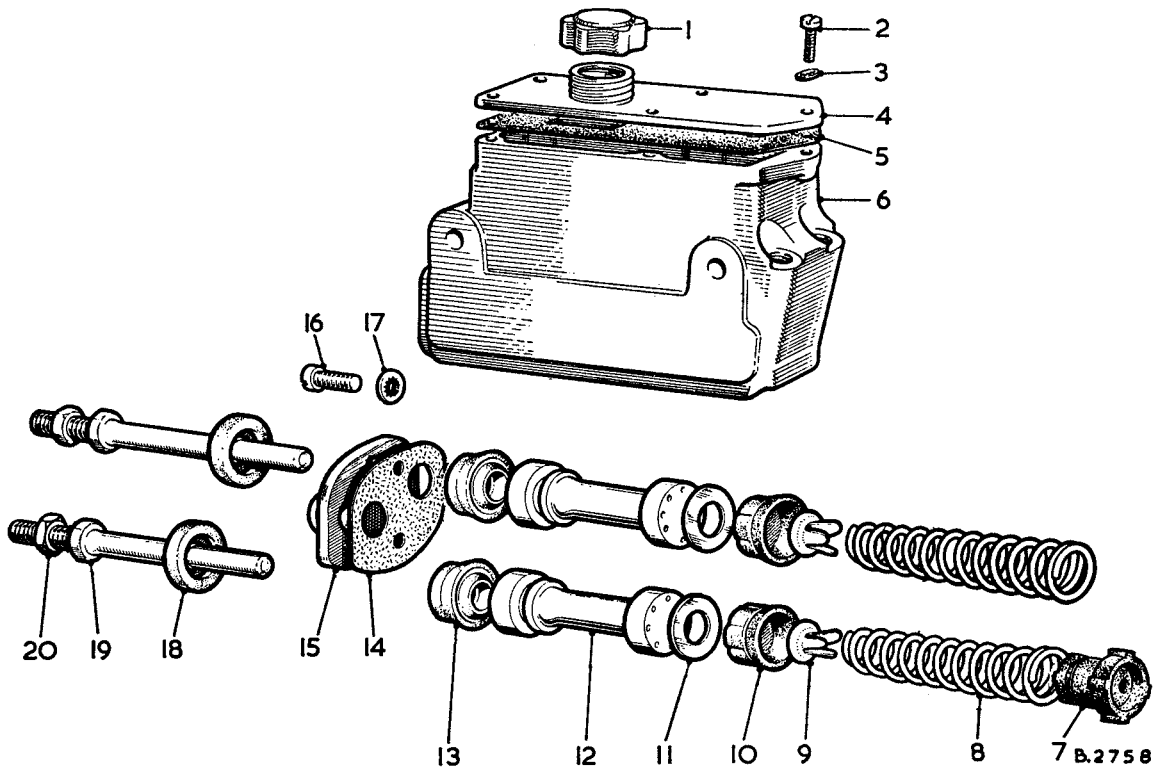

Fig. M.5

Master cylinder exploded

- | | | |
|------------------------------|---------------------|------------------------|
| 1. Filler cap. | 8. Return spring. | 15. Boot fixing plate. |
| 2. Fixing screw. | 9. Spring retainer. | 16. Fixing screws. |
| 3. Shakeproof washer. | 10. Main cup. | 17. Shakeproof washer. |
| 4. Tank cover. | 11. Piston washer. | 18. Boot. |
| 5. Tank cover gasket. | 12. Piston. | 19. Push-rod. |
| 6. Cylinder barrel and tank. | 13. Secondary cup. | 20. Push-rod adjuster. |
| 7. Valve (Brake bore only). | 14. Gasket. | |

move. The push-rod must have a minimum of $\frac{1}{32}$ in. (.8 mm.) free movement before the piston starts to move.

Section M.4

BLEEDING THE SYSTEM

The following procedure must be followed after any service operation or fault in the braking system which may have allowed air to enter the hydraulic system.

During the bleeding operation it is most important that the master cylinder reservoir is kept at least half-full to avoid drawing air into the system.

- (1) Check that all connections are tightened and all bleed screws closed.
- (2) Fill the reservoir with the recommended brake fluid (see 'GENERAL DATA').
- (3) Remove the rubber cap from the rear bleed screw on the wheel cylinder farthest from the master cylinder, and fit a bleed tube to the screw.
- (4) Immerse the free end of the tube in a clean glass containing a small quantity of brake fluid.
- (5) Slacken the bleed screw and depress the brake pedal slowly through its full travel and allow it to return without assistance.
- (6) Repeat the pedal pumping action with a slight pause before each depression of the pedal.
- (7) When the fluid leaving the bleed tube is completely

free of air bubbles, hold the pedal down firmly and tighten the bleed screw.

- (8) Repeat the operations in (3) to (7) on all the remaining wheel cylinders, finishing at the wheel nearest the master cylinder.
- (9) Top up the reservoir to the correct level.
- (10) Apply a normal work load to the brake pedal for a period of two or three minutes and examine the entire system for leaks.

Section M.5

MASTER CYLINDER

Removing

- (1) Disconnect the electrical connections from the heater blower unit, remove the screws securing the blower unit to the bulkhead and remove the blower unit.
- (2) Remove the screws securing the master cylinder mounting plate to the bulkhead.
- (3) Disconnect the two hydraulic pipes from their unions on the master cylinder. Note which one of the pipes connects to the clutch slave cylinder.
- (4) Withdraw the master cylinder upwards and at the same time manipulate the clutch and brake pedals through the hole in the bulkhead.
- (5) Remove the spring clips, and withdraw the clevis pins from the push-rods to disconnect both pedals.

- (6) Unscrew the bolts securing the master cylinder to the mounting plate and remove the complete unit.

Dismantling

- (7) Remove the filler cap and drain the fluid.
- (8) Remove screws retaining the boot fixing plate to the master cylinder.
- (9) Detach the fixing plate and remove the boots and push-rods.
- (10) Withdraw the piston, piston washer, main cup, and return spring complete with spring retainer and valve assembly from the brake bore of the cylinder.
- (11) Remove the secondary cup from the piston by stretching it over the end flange.

Inspection

- (12) Clean all the parts thoroughly using the recommended brake fluid and dry them with a clean, non-fluffy cloth.
- (13) Examine the metal parts for wear and damage, inspect the rubber cups for swelling, perishing, distortion, or any other signs of deterioration. Renew all worn, damaged, or suspect parts.

Reassembling

- (14) Dip all the internal components in the recommended brake fluid and assemble them while wet.
- (15) Stretch the secondary cup over the piston with the lip of the cup facing towards the head of the piston. When the cup is in its groove work round it with the fingers to ensure that it is correctly seated.
- (16) Fit the spring retainer into the small diameter end of the spring and the valve assembly into the large diameter end.
- (17) Insert the assembled spring into the body, valve assembly end first.

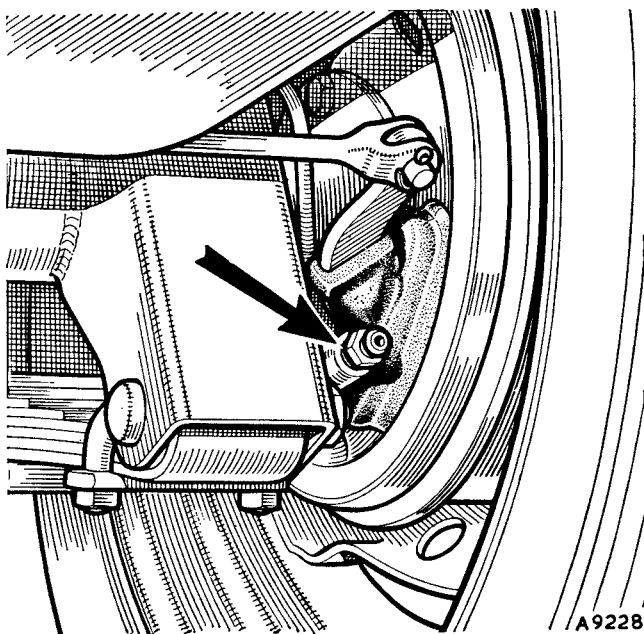

Fig. M.6

Illustrating a rear brake bleed nipple

Sprite and Midget. Issue 2. 4780

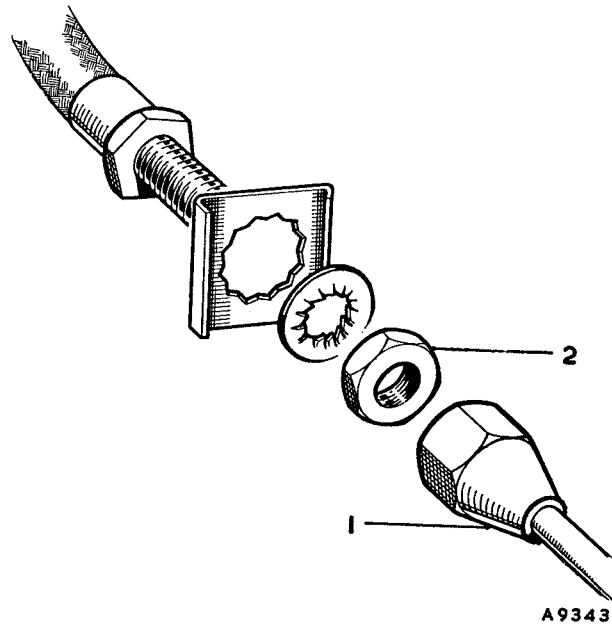

Fig. M.7

The union nut (1) is the one which must be first unscrewed to release the flexible hose from the pipeline. The attachment nut (2) can then be removed

- (18) Fit the main cup, piston washer, and piston. When fitting the cups carefully enter the lip edge of the cups into the barrel first.
- (19) Fit the boot fixing plate, boots, and push-rods. Each boot must be fitted with the vent hole at the bottom when the master cylinder is mounted in the car.

Refitting

- (20) Reverse the removing procedure in (1) to (6) then bleed the system (Section M.4).

Section M.6

BRAKE PEDAL

Removing

- (1) Raise the bonnet and remove the spring clips and clevis pins connecting the clutch and brake pedals to the master cylinder push-rods.
- (2) From inside the car, detach the pedal return springs and remove the nut and spring washer retaining the pedal fulcrum pin.
- (3) Withdraw the fulcrum pin and remove the pedals and distance piece.

Inspection

- (4) Examine the pedal and fulcrum pin for excessive wear and renew the worn parts as necessary.

Refitting

- (5) Reverse the removing procedure in (1) to (3) noting that the distance piece is fitted between the pedals.

M.9

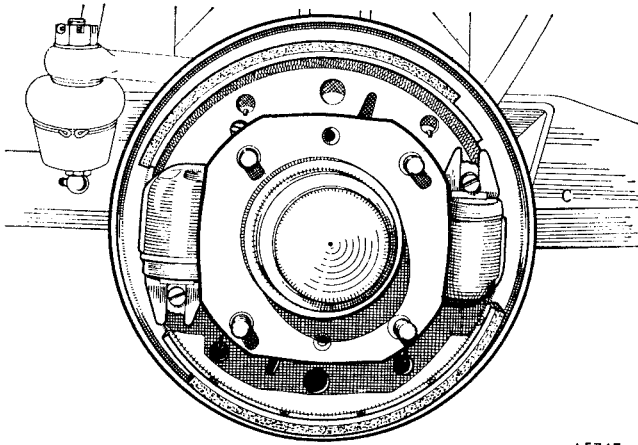

A5747

Fig. M.8

The front brake assembly

Section M.7

FLEXIBLE HOSES

Removing

- (1) Unscrew the pipe union nut from its connection to the hose.
- (2) Hold the hexagon on the flexible hose and remove the locknut and shakeproof washer securing the hose union to the bracket.
- (3) Unscrew the flexible hose from the cylinder.

Refitting

- (4) Reverse the removing procedure in (1) to (3).

Section M.8

FRONT BRAKE ASSEMBLIES—DRUM BRAKES

Removing

Brake-shoes

- (1) Raise the front of the car and remove the road wheel.
- (2) Remove the countersunk screw (disc wheels) or nuts (wire wheels) securing the brake-drum and withdraw the drum.
- (3) Lift one brake-shoe, against the tension of the return springs, from its abutment with the closed end of one of the wheel cylinders, and slide the Micram mask off the piston cover of the other cylinder.
- (4) With the return spring tension released detach the springs and remove both shoes.

Wheel cylinders

- (5) Carry out the operations in (1) to (4).
- (6) Disconnect the hydraulic bridge pipe from the wheel cylinders.
- (7) Remove the bolts securing the wheel cylinder to the backplate and withdraw the cylinder from the backplate.

M.10

Backplate

- (8) Carry out the operations in (1) and (2).
- (9) Lever off the hub cap.
- (10) Withdraw the split pin locking the hub retaining nut, and remove the nut and washer.
- (11) Withdraw the hub assembly from the swivel axle using tool 18G 304 with adaptors 18G 304 F.
- (12) Disconnect the hydraulic feed pipe from the backplate.
- (13) Unscrew the bolts securing the backplate to the swivel axle and remove the backplate and brake assembly.

Dismantling

Wheel cylinder

- (14) Withdraw the piston, complete with its cover, from the cylinder.
- (15) Apply a gentle air pressure to the fluid connection and blow out the rubber cup, cup filler, and spring.
- (16) Remove the sealing ring.
- (17) Remove the bleed screw.

Inspection

Brake-shoes

- (18) Clean the dust from the brake-shoes and linings using an air blast, examine the linings for wear. See Section M.11 for brake-shoe relining.

Wheel cylinders

- (19) Clean the components thoroughly using the recommended brake fluid, and dry them with a clean, non-fluffy cloth.
- (20) Examine the metal parts for wear and damage, inspect the rubber cup for swelling or signs of deterioration. Renew all damaged, worn or suspect parts.

Reassembling

Wheel cylinders

- (21) Dip the components in the recommended brake fluid and assemble them wet.
- (22) Fit the cup filler into the small diameter end of the spring and insert the spring, large diameter end first, into the cylinder.
- (23) Fit the cup, lip side first, into the cylinder.
- (24) Fit the piston and piston cover.

Refitting

Backplate

- (25) Reverse the removing procedure in (8) to (13) then bleed the system (Section M.4) and adjust the brake-shoes (Section M.2).

Wheel cylinders

- (26) Reverse the removing procedure in (5) to (7), then bleed the system (Section M.4) and adjust the brake-shoes (Section M.2).

Brake-shoes

- (27) Reverse the removing procedure in (1) to (4) then adjust the brake-shoes (Section M.2).

Section M.9

FRONT BRAKE ASSEMBLIES—DISC BRAKES

Removing

Friction pads

- (1) Raise the front of the car and remove the road wheel.
- (2) Depress the friction pad retaining spring and withdraw the split pins.
- (3) Remove the retaining springs.
- (4) Rotate the friction pads and anti-squeak shims slightly, and lift them from the calliper.

Calliper assembly

- (5) Carry out the operations in (1) to (4).
- (6) Disconnect the hydraulic supply hose.
- (7) Remove the nuts securing the hose retaining plate to the calliper.
- (8) Remove the studs securing the calliper to the stub axle and withdraw the calliper.

Brake discs

- (9) Carry out the operations in (1) to (8).
- (10) Remove the hub cap and withdraw the split pin locking the hub retaining nut.
- (11) Remove the retaining nut and washer.
- (12) Withdraw the hub complete with the brake disc from the swivel axle using tool 18G 304 with adaptors 18G 304 F (disc wheels) or tool 18G 363 (wire wheels—early cars) or 18G 1032 (wire wheels—later cars).
- (13) Remove the bolts securing the brake disc to the hub, and remove the disc.

Calliper pistons and seals

- (14) Carry out the operations in (1) to (8).
- (15) Clean the outside of the calliper, ensuring that all dirt and cleaning fluid are completely removed.
- (16) Note the position of the relieved portion of the piston face.
- (17) Reconnect the hydraulic supply hose and support the calliper to avoid strain on the hose.
- (18) Using tool 18G 590 clamp the piston in the mounting half of the calliper.
- (19) Place a receptacle under the calliper and gently press the brake pedal until the piston in the rim half has emerged sufficiently for it to be removed by hand.
- (20) Withdraw the piston.
- (21) Gently prise the dust seal retainer from the mouth of the calliper bore and remove the dust seal taking care not to damage the seal groove.
- (22) Remove the fluid seal from its groove in the calliper bore taking great care not to damage the bore of the calliper or the seal groove.
- (23) Remove the clamping tool.
- (24) To remove the mounting-half piston it is first necessary to refit the lip-half piston then repeat the procedure in (18) to (22) but with the lip-half piston clamped.

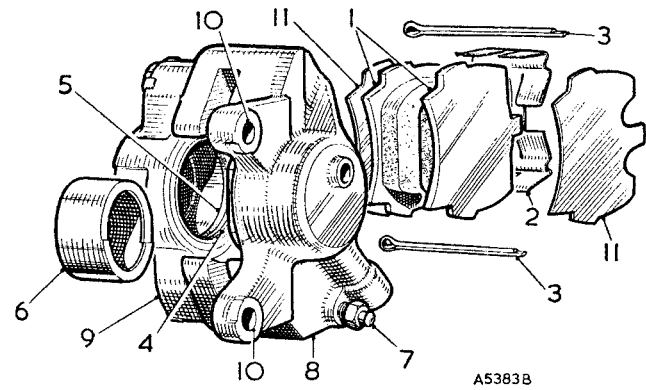

Fig. M.9

The front brake calliper components

- | | |
|--------------------------|------------------------------|
| 1. Friction pads. | 6. Piston. |
| 2. Pad retaining spring. | 7. Bleeder screw. |
| 3. Retaining pin. | 8. Calliper (mounting half). |
| 4. Piston dust seal. | 9. Calliper (rim half). |
| 5. Piston fluid seal. | 10. Calliper mounting point. |
| | 11. Anti-squeak shims. |

Dismantling

Calliper assembly

- (25) Remove the bleeder screw.

NOTE.—Unless it is absolutely unavoidable the calliper should not be separated into two halves. In the event of separation becoming essential, the fluid channel seal, clamping bolts, and lock plates must be renewed when reassembling. Only bolts supplied by (Austin-Morris) Service division may be used. On assembly these must be tightened with a torque wrench set at between 33.5 and 37 lb. ft. (4.9 and 5.1 kg. m.).

Ensure that the calliper faces are clean and that the threaded bolt holes are thoroughly dry. Make certain that the new fluid seal is correctly located in the recessed face before assembling the two calliper halves.

Inspection

Friction pads

- (26) Examine the lining material for wear, if the material is worn down to a maximum permissible thickness of $\frac{1}{8}$ in. (1.59 mm.) the friction pads must be renewed.
- (27) Check that the friction pads move easily in the calliper recess, remove any high spots from the pad pressure plates by careful filing.
- (28) Examine the pad retaining springs for damage or loss of tension, renew the springs as necessary.

Calliper assembly

- (29) Clean any dirt or rust from the friction pad recesses. Thoroughly clean the exposed faces of the pistons or bores. Use only the recommended brake fluid or methylated spirit for cleaning, solvents must not be used.
- (30) Blow the fluid passages clear with compressed air.

Reassembling

Calliper assembly

- (31) Refit the bleeder screw.

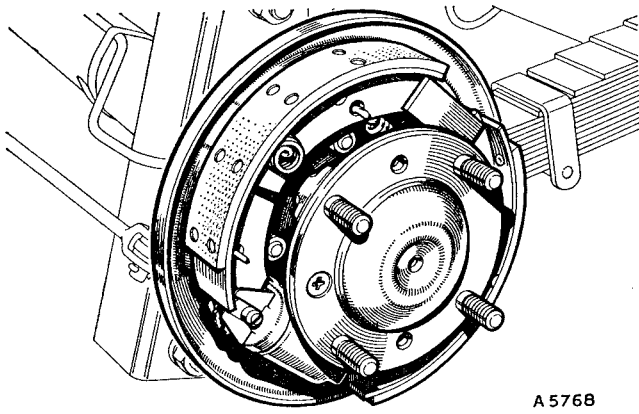

Fig. M.10
The rear brake assembly

Refitting

Brake disc

- (32) Refit the brake disc to the hub.
- (33) Fit the hub assembly to the stub axle.
- (34) Check the maximum run-out of the brake disc at the periphery of the braking surface, if the run-out exceeds .006 in. (.152 mm.) the components must be examined for damage and, if necessary, renewed.

Calliper pistons and seals

- (35) Ensure that the new fluid seal is absolutely dry, and coat it with Lockheed Disc Brake Lubricant.
- (36) Ease the seal into its groove in the calliper bore, then gently work round with the fingers until it is seating correctly.
- (37) Slacken the bleeder screw one complete turn.
- (38) Coat the piston with Lockheed Disc Brake Lubricant and locate the piston squarely in the mouth of the bore, with the cut-away portion of the piston face correctly positioned downwards.
- (39) Press the piston into the bore until approximately $\frac{1}{8}$ in. (8 mm.) of the piston is protruding from the bore. Take great care to prevent the piston from lifting during this operation.
- (40) Ensure that the new dust seal is absolutely dry, coat it with Lockheed Disc Brake Lubricant and fit the seal into its retainer.
- (41) Position the seal assembly on the protruding portion of the piston with the seal innermost, ensuring that the assembly is square with the piston.
- (42) Using tool 18G 590, press the piston and seal assembly home.
- (43) Retighten the bleeder screw.
- (44) Fit the seals and pistons into the mounting half of the calliper by the same procedure as in (34) to (42), noting that the hydraulic feed pipe must be disconnected to allow the clamping tool to be used.

Calliper assembly

- (45) Reverse the removing procedure in (6) to (8), noting that the brake pedal must not be depressed.

Friction pads

- (46) Check that the exposed surface of each piston is clean and the recesses in the calliper are free from rust and grit.

M.12

- (47) Using tool 18G 590 press each piston fully back into the bore.

NOTE.—During this operation, fluid displaced by the pistons will cause the fluid level in the master cylinder to rise, and it may be necessary to siphon off some of the fluid to prevent it from overflowing.

- (48) Check that the relieved face of each piston is correctly positioned downwards, and fit the friction pads into the calliper.
- (49) Check that the friction pads are free to move easily in the calliper recesses and fit the anti-squeak shims between the pistons and friction pad pressure plates.
- (50) Fit the pad retaining springs, press the spring down and insert the split pins.
- (51) Bleed the system (Section M.4).
- (52) Pump the brake pedal several times to adjust the friction pads and top up the master cylinder reservoir to the correct level.

Section M.10

REAR BRAKE ASSEMBLIES

Removing

Brake-shoes (early cars)

- (1) Block both front wheels, fully release the hand brake, and raise the rear of the car.
- (2) Remove the road wheel.
- (3) Back off the brake-shoe adjuster and remove the brake-drum (see Section H.3).
- (4) Depress each shoe steady spring, turn it, to release it from the backplate.
- (5) Pull the trailing shoe, against the tension of the return springs, away from its abutment at either end.
- (6) With the return spring tension released detach the springs and remove both shoes. The Micram adjuster will also come free when the shoes are removed.

Brake-shoes (later cars)

- (7) Carry out the operations in (1) to (3) and (5).
- (8) Remove the shoes and springs.

Wheel cylinder (early cars)

- (9) Remove the brake-shoes as detailed in (1) to (6).
- (10) Disconnect the hydraulic feed pipe at the wheel cylinder.
- (11) Disconnect the hand brake rod at the wheel cylinder lever.
- (12) Remove the rubber boot.
- (13) Withdraw the piston and cover from the wheel cylinder.
- (14) Swing the hand brake lever until the shoulder is clear of the backplate, and slide the cylinder assembly forward.
- (15) Pivot the cylinder about its forward end and withdraw the rear end from the slot in the backplate.
- (16) Move the cylinder rearwards and disengage the forward end from the backplate.

Wheel cylinder (later cars)

- (17) Remove the brake-shoes as detailed in (7) and (8).

Sprite and Midget. Issue 4. 29459

- (18) Disconnect the hydraulic feed pipe at the wheel cylinder.
- (19) Disconnect the hand brake rod from the wheel cylinder lever and remove the rubber boot.
- (20) Remove the bleed screw.
- (21) Remove the circlip retaining the wheel cylinder to the backplate and withdraw the cylinder assembly.

Backplate

- (22) Remove the wheel cylinder as detailed in (9) to (16) (early cars) or (17) to (21) (later cars).
- (23) Remove the axle shaft (Section H.3).
- (24) Remove the hub assembly (Section H.4).
- (25) Unscrew the bolts securing the backplate to the hub, and remove the backplate.

Dismantling

Wheel cylinders (early cars)

- (26) Withdraw the hand brake lever pivot pin and remove the lever.
- (27) Apply a gentle air pressure to the fluid connection and blow out the hydraulic piston, rubber cup, cup filler, and spring.
- (28) Remove the seal from the outer piston.

Wheel cylinders (later cars)

- (29) Remove the dust seals from the ends of the cylinder.
- (30) Withdraw both pistons complete with their seals.
- (31) Withdraw the hand brake lever pivot pin and remove the lever.
- (32) Remove the seals from the pistons.

Inspection

Brake-shoes

- (33) Clean the dust from the brake-shoes and linings using an air blast, and examine the linings for wear. See Section M.11 for brake-shoe relining.

Wheel cylinders

- (34) Clean the components thoroughly using the recommended brake fluid, and dry them with a clean, non-fluffy cloth.
- (35) Examine the metal parts for wear and damage.
- (36) Inspect the rubber cup and seals for swelling or signs of deterioration.
- (37) Renew all damaged, worn, or suspect parts.

Reassembling

Wheel cylinders (early cars)

- (38) Dip the internal components in the recommended brake fluid and assemble them wet.
- (39) Fit the small diameter end of the spring into the cup filler and insert the spring, large diameter end first, into the cylinder.
- (40) Fit the cup, lip side first, into the cylinder.
- (41) Insert the hydraulic piston, aligning the slot in the piston with the slot in the cylinder.
- (42) Fit the hand brake lever and pivot pin.
- (43) Ease the seal into its groove in the outer piston.
- (44) Fit the outer piston assembly.

Wheel cylinders (later cars)

- (45) Dip the internal components in the recommended brake fluid and assemble them wet.
- (46) Fit the seals to the pistons.

- (47) Insert the pistons and fit the dust covers
- (48) Fit the hand brake lever and pivot pin.

Refitting

Backplate

- (49) Reverse the removing procedure in (22) to (25), bleed the system and adjust the brake-shoes.

Wheel cylinders (early cars)

- (50) Reverse the removing procedure in (9) to (16), bleed the system and adjust the brake-shoes.

Wheel cylinders (later cars)

- (51) Reverse the removing procedure in (17) to (21), bleed the system and adjust the brake-shoes.

Brake-shoes (early cars)

- (52) Reverse the removing procedure in (1) to (6), noting the following.
 - (a) Ensure that the Micram adjuster is in the slot in the leading shoe with the mask in position.
 - (b) The interrupted return spring must be fitted on the wheel cylinder side and both springs must lie between the brake-shoes and backplate.
 - (c) The shoes must be fitted with the unlined end of the leading shoe to the wheel cylinder, and the unlined end of the trailing shoe to the abutment block.

Brake-shoes (later cars)

- (53) Reverse the removing procedure in (7) and (8), noting the following.
 - (a) Ensure that the brake-shoes register correctly in the slots in the wheel cylinder pistons and on the adjuster tappets.
 - (b) Ensure that the return springs are anchored in their correct holes in the shoe webs, with the interrupted spring fitted on the wheel cylinder side.
 - (c) After refitting adjust the brake-shoes.

Section M.11

BRAKE-SHOE RELINING

It is not recommended that brake-shoes relining is undertaken unless all the special facilities necessary to carry out the work are available. Where the facilities are not available it is recommended that replacement brake-shoes are used.

When fitting new linings or replacement brake-shoes the following points must be observed.

- (1) Only linings and replacement shoes with linings of the material specified in 'GENERAL DATA' must be used.
- (2) Shoes or linings must only be renewed in sets.
- (3) After riveting new linings to the brake-shoes it is essential that any high-spots are removed before refitting the shoes to the backplate.
- (4) When new brake-shoes or linings have been fitted the brake-shoe adjusters must be fully backed off and the hand brake fully released before attempting to fit the brake-drum over the new linings.
- (5) Do not allow oil, grease, brake fluid, or paint to come into contact with the brake linings.

SECTION Ma

THE BRAKING SYSTEM

The information given in this Section refers specifically to the Sprite (Mk. IV) and Midget (Mk. III) and must be used in conjunction with Section M.

	<i>Section</i>
Master cylinder	Ma.1

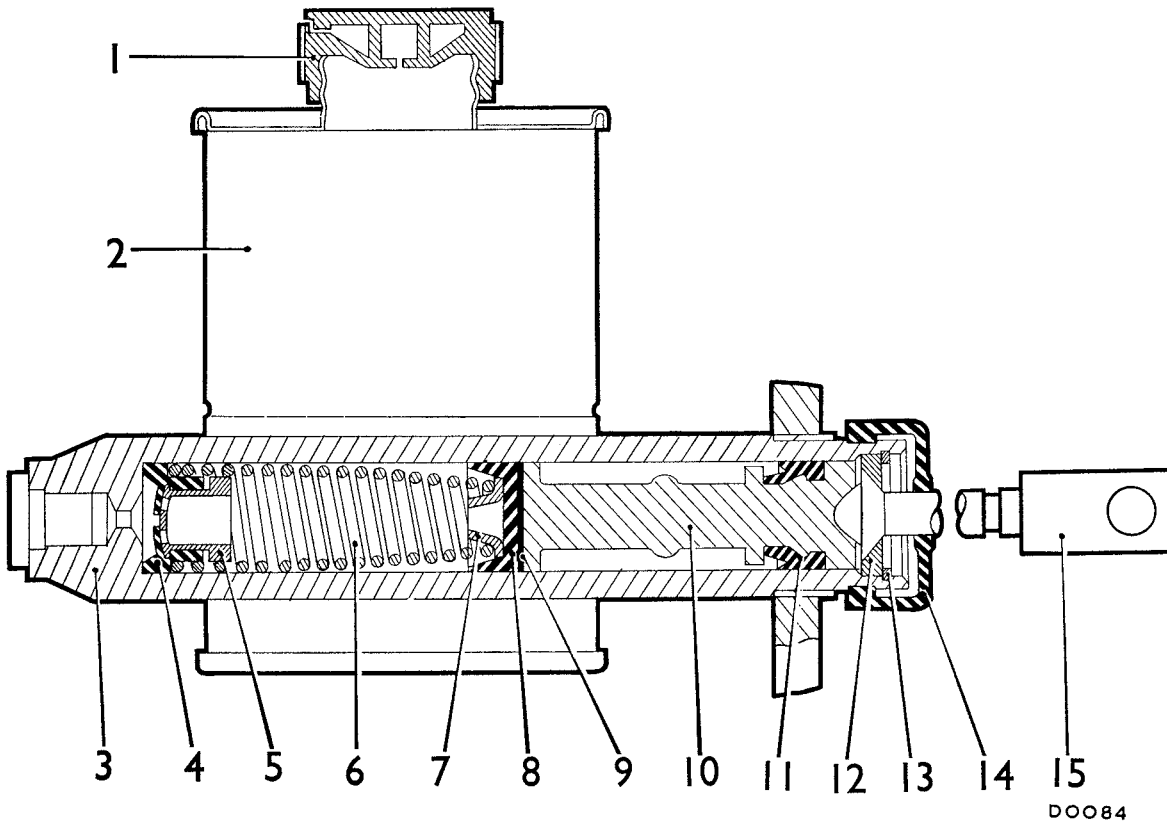

Fig. Ma.1

A section through the master cylinder

- | | | | |
|----------------|---------------------|--------------------|------------------|
| 1. Filler cap. | 5. Valve seat. | 9. Piston washer. | 13. Circlip. |
| 2. Reservoir. | 6. Spring. | 10. Piston. | 14. Rubber boot. |
| 3. Body. | 7. Spring retainer. | 11. Secondary cup. | 15. Push-rod. |
| 4. Valve. | 8. Main cup. | 12. Dished washer. | |

DO084

Section Ma.1

MASTER CYLINDER

Removing

- (1) Raise the bonnet and remove the pedal box lid.
- (2) Disconnect the hydraulic pipe from the brake master cylinder.
- (3) Withdraw the split pin from the clevis pin connecting the push-rod to the brake pedal and remove the clevis pin.
- (4) Unscrew the two bolts securing the master cylinder to the pedal box and remove the master cylinder.

Dismantling

- (5) Remove the filler cap and drain the fluid.
- (6) Detach the rubber boot from the body and slide it up the push-rod.
- (7) Remove the circlip retaining the push-rod, and withdraw the push-rod complete with the rubber boot and dished washer.
- (8) Withdraw the piston complete with the secondary cup.
- (9) Remove the piston washer, main cup, and the spring complete with the spring retainer and valve.
- (10) Remove the secondary cup from the piston by carefully stretching it over the end flange of the piston using only the fingers.

Inspection

- (11) Clean all the parts thoroughly using the recom-

mended brake fluid and dry them with a clean non-fluffy cloth.

- (12) Examine the metal parts for wear and damage, inspect the rubber components for swelling, perishing, distortion, or any other signs of deterioration. Renew all worn, damaged, or suspect parts.

Reassembling

- (13) Dip all the internal components in the recommended brake fluid and assemble them while wet.
- (14) Stretch the secondary cup over the piston with the lip of the cup facing towards the head of the piston. When the cup is in its groove, work round it gently with the fingers to ensure that it is correctly seated.
- (15) Fit the spring retainer and the valve to the spring, and fit spring, valve end first, into the body.
- (16) Fit the main cup, cup washer, piston and push-rod. When fitting the cups carefully enter the lip edge of the cup into the barrel first.
- (17) Fit the circlip and rubber boot.

Refitting

- (18) Reverse the removing procedure in (1) to (4) then fill the master cylinder with the recommended brake fluid (see 'GENERAL DATA') and bleed the system (Section M.4).

Section Mb

THE BRAKING SYSTEM (Tandem Master Cylinder)

The information given in this Section refers specifically to service operations on, or affected by equipment fitted to the Sprite Mk. IV and Midget Mk. III in conformity with local and territorial requirements, and must be used in conjunction with Section M and Section Ma.

	<i>Section</i>
Master cylinder	Mb.2
Pedal free movement	Mb.1
Pressure failure switch assembly	Mb.3

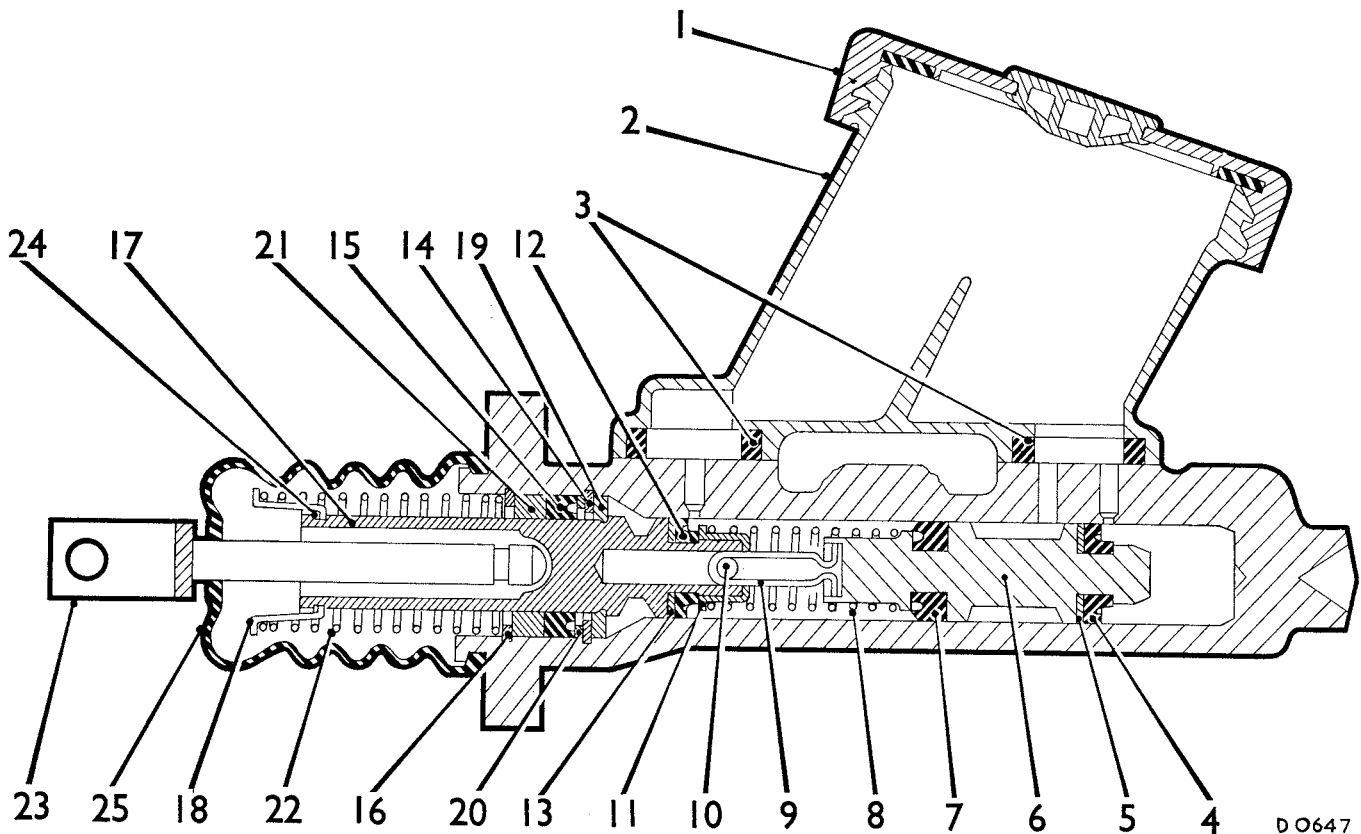

Fig. Mb.1

A section through the master cylinder

- | | | | |
|-----------------------|-------------------|----------------------|----------------------|
| 1. Filler cap. | 7. Main cup. | 13. Piston washer. | 19. Stop washer. |
| 2. Plastic reservoir. | 8. Spring. | 14. Circlip. | 20. Washer. |
| 3. Reservoir seals. | 9. Piston link. | 15. Cup. | 21. Bearing. |
| 4. Main cup. | 10. Pin. | 16. Circlip. | 22. Spring. |
| 5. Piston washer. | 11. Pin retainer. | 17. Piston. | 23. Push-rod. |
| 6. Piston. | 12. Main cup. | 18. Spring retainer. | 24. 'Spirolox' ring. |
| | 25. Rubber boot. | | |

Section Mb.1

PEDAL FREE MOVEMENT

A free movement of $\frac{1}{8}$ in. (3.2 mm.) measured at the pedal pad must be maintained on the brake pedal.

To adjust the free movement, slacken the stop light switch locknut, and turn the switch clockwise to decrease or anti-clockwise to increase the clearance. Tighten the switch locknut.

Section Mb.2

MASTER CYLINDER

Removing

- (1) Unscrew the four retaining screws and remove the pedal box cover.
- (2) Disconnect the hydraulic pipes from the master cylinder.
- (3) Withdraw the split pin from the push-rod clevis pin and remove the clevis pin.
- (4) Unscrew the two bolts securing the master cylinder to the pedal box and remove the master cylinder.

Mb.2

Dismantling

- (5) Drain the fluid from the reservoir and refit the cap.
- (6) Plug the pipe connections and thoroughly clean the exterior of the assembly.
- (7) Detach the rubber boot and withdraw the push-rod.
- (8) Grip the cylinder body in a soft-jawed vice with the mouth of the bore uppermost.
- (9) Compress the return spring and remove the 'Spirolox' ring from its groove in the primary piston, taking care not to distort the coils of the ring or score the bore of the cylinder.
- (10) Using tool 18G 1112 remove the piston retaining circlip. A slight radiusing of the sides of the tool may be necessary for ease of use on this master cylinder.
- (11) Move the piston up and down in the bore to free the nylon guide bearing and cap seal, remove the guide bearing and seal.
- (12) Remove the plain washer.
- (13) Using tool 18G 1112 remove the inner circlip.
- (14) Withdraw the primary and secondary piston assembly complete with stop washer.

- (15) Remove the stop washer.
- (16) Compress the spring separating the two pistons and drive out the roll-pin retaining the piston link.
- (17) Note the positions of the rubber caps by their moulded indentations and remove the cups and washers from the pistons.
- (18) Unscrew the four bolts securing the plastic reservoir to the body and remove the reservoir.
- (19) Remove the two reservoir sealing rings.
- (20) Unscrew the connection adaptors, discard the copper gaskets, and remove the springs and trap valves.

Inspection

- (21) Clean all the parts thoroughly using the recommended brake fluid and dry them with clean lint-free cloth.
- (22) Examine the metal parts for wear and damage, inspect the rubber components for swelling, perishing, distortion, or any other signs of deterioration. Renew all worn, damaged, or suspect parts.

Reassembling

- (23) Dip all the internal components in the recommended brake fluid and assemble them while wet.
- (24) Locate the piston washer on the head of the secondary piston, convex surface first.
- (25) Carefully ease the secondary main cup, lip last, over the end of the piston, using the fingers, and seat it correctly in the groove adjacent to the washer.
- (26) Carry out the operations in (24) and (25) with the washer and main cup of the primary piston.
- (27) Reverse the dismantling procedure in (5) to (16) and (18) to (20).

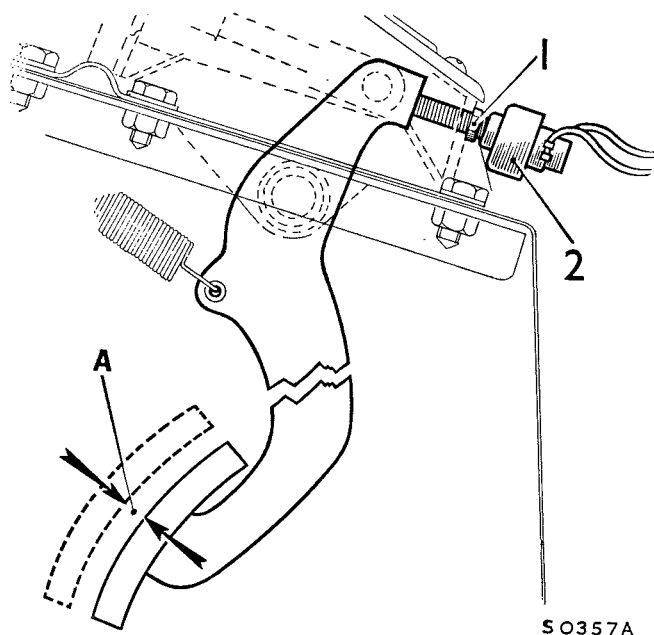

Fig Mb.2

Brake pedal adjustment

1. Switch locknut.
 2. Stop light switch.
- A = 1/4 in. (3.2 mm.)

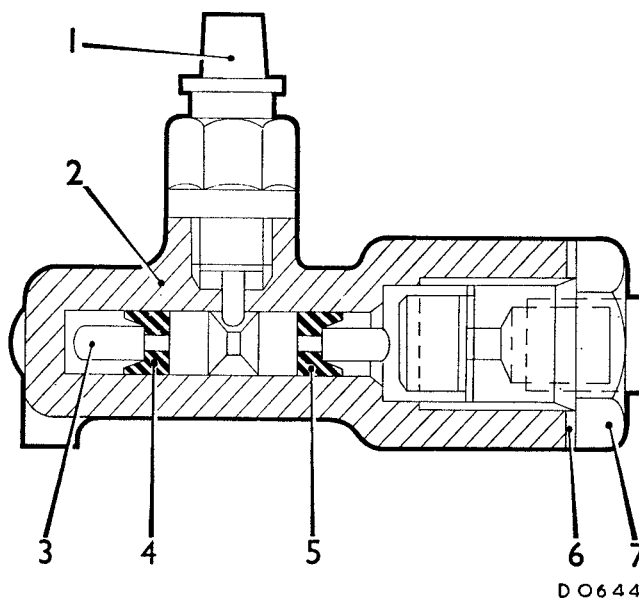

Fig. Mb.3

A section through the pressure failure switch assembly

- | | |
|--------------------------|-------------------|
| 1. Nylon switch. | 4. Piston seal. |
| 2. Switch body. | 5. Piston seal. |
| 3. Shuttle valve piston. | 6. Copper washer. |
| | 7. End plug. |

Refitting

- (28) Reverse the removing procedure in (1) to (4), fill the master cylinder with the recommended brake fluid (see 'GENERAL DATA') and bleed the system (see Section M.4) commencing with the rear brakes. Check, and, if necessary adjust the brake pedal free movement (Section Mb.1).

Section Mb.3

PRESSURE FAILURE SWITCH ASSEMBLY

Removing

- (1) Disconnect the wiring from the switch.
- (2) Clean the switch assembly and its adjacent surroundings particularly the pipe connections.
- (3) Disconnect the plug and hydraulic pipes.
- (4) Unscrew the retaining bolt and remove the assembly.

Dismantling

- (5) Remove the end plug and discard the copper washer.
- (6) Unscrew the nylon switch.
- (7) Withdraw the shuttle valve piston assembly from the bore; use a low pressure air line to free the piston if necessary.
- (8) Remove and discard the two piston seals.

Inspection

- (9) Thoroughly clean all the components using Methylated Spirit (denatured alcohol) or the

recommended brake fluid, and dry with lint-free cloth.

- (10) Inspect the bore of the casing for scoring and damage, the complete assembly must be renewed if the bore is not in a perfect condition.
- (11) Reconnect the wiring to the switch and actuate the switch plunger, with the ignition switched on, to test the switch operation and warning light circuit.

Reassembling

- (12) Fit two new seals, lips facing outwards, to the piston.
- (13) Lubricate the piston assembly with Lockheed Disc Brake lubricant and fit the piston into the bore taking care that the lip of the leading seal is not turned back.

- (14) Fit a new copper washer to the end plug, screw in and tighten the plug to the torque figure given in 'GENERAL DATA'.

- (15) Screw in the switch and carefully tighten it to the torque figure given in 'GENERAL DATA'.

Refitting

- (16) Reverse the removing procedure in (1) to (4), fill the master cylinder with the recommended brake fluid (see 'GENERAL DATA') and bleed the system (see Section M.4) commencing with the rear brakes.