

SECTION 4

CARBURETTERS

	<i>Section</i>
Type HS Carburetters	
Carburetter servicing	4-B
Carburetter tuning—Basic	4-A
Single carburetters	
Twin carburetters	
Carburetter tuning—Complete	4-C
Single carburetters	
Twin carburetters	
Type HIF Carburetters	
Overhauling	4-E
Tuning	4-D

CARBURETTERS

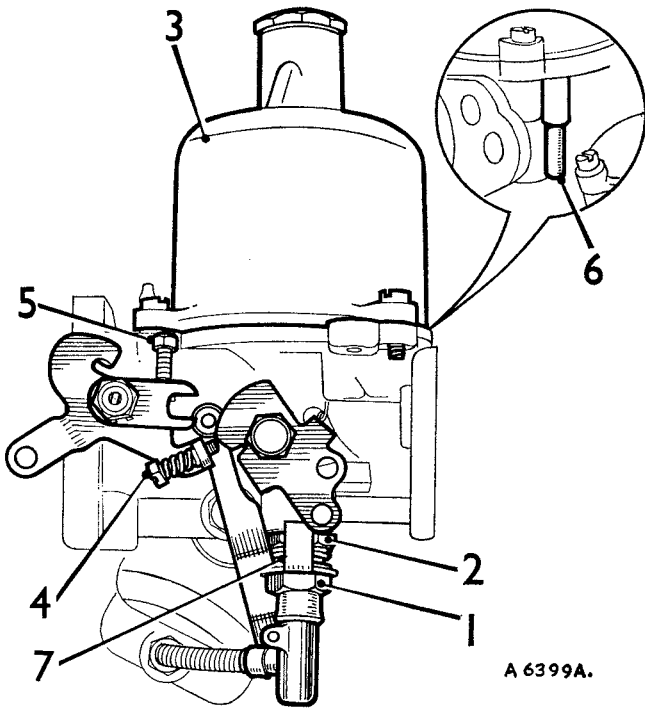

The type HS carburettor

- | | |
|-------------------------------|-------------------------------|
| 1. Jet adjusting nut. | 4. Fast-idle adjusting screw. |
| 2. Jet locking nut. | 5. Throttle adjusting screw. |
| 3. Piston suction chamber. | 6. Piston lifting pin. |
| 7. Jet adjustment restrictor. | |

Section 4-A

CARBURETTER TUNING—BASIC

GENERAL

The carburetters fitted to cars equipped with engine emission control systems are balanced to provide maximum performance with maximum pollution control. Under no circumstances may they be interchanged, or parts substituted.

Tuning must be carried out with the engine emission control equipment connected and operating, and is confined to the following procedure. If the required settings cannot be obtained, the service procedure detailed under 'CARBURETTER SERVICING' must be carried out and then the carburettor tuned in accordance with the procedure given in 'CARBURETTER TUNING—COMPLETE'.

Tuning conditions

To ensure that the engine temperature and mixture requirements are stabilized, tuning must be carried out in accordance with the following setting cycle.

- (1) Connect a tachometer in accordance with the instrument-maker's instructions.
- (2) Warm the engine at a fast idle to normal operating temperature, preferably with the car standing in an ambient temperature of between 16 and 27° C. (60 to 80° F.). Run the engine for at least five minutes after the thermostat has opened; the

thermostat opening point can be detected by the sudden rise in temperature of the radiator header tank.

- (3) Set the engine speed at 2,500 r.p.m., at no load, and run for one minute.
- (4) Tuning operations may now be commenced and must be carried out in the shortest possible time. If the time for settings exceeds a three-minute period, open the throttle and run the engine at 2,500 r.p.m. for one minute then resume tuning. Repeat this clearing operation if further periods of three minutes are exceeded.

SINGLE CARBURETTERS

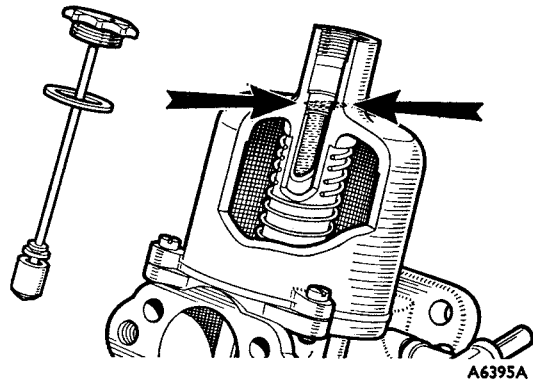

NOTE.—In no case should the jet adjustment restrictor be removed or repositioned. Only mixture adjustments within the limits of the restrictor are available for tuning. If satisfactory adjustment is not obtainable within the limits of the jet adjustment restrictor refer to 'CARBURETTER SERVICING'.

- (1) Top up the piston damper with the recommended engine oil until the level is $\frac{1}{2}$ -in. above the top of the hollow piston rod.

NOTE.—On dust-proofed carburetters, identified by a transverse hole drilled in the neck of the suction chambers and no vent hole in the damper cap, the oil level must be $\frac{1}{2}$ -in. below the top of the hollow piston rod.

- (2) Check throttle control action for signs of sticking.
- (3) Check the idling speed (Tachometer) against the figure given in 'TUNING DATA'.
 - (a) If the reading is correct and the engine runs smoothly, proceed to operations (7) and (8).
 - (b) If the reading is not correct, adjust the speed by turning the throttle adjusting screw in the required direction until the correct speed consistent with smooth running is obtained, then proceed to operations (7) and (8).
 - (c) If a smooth idle at the correct speed is not obtainable by turning the throttle adjusting screw, carry out operations (4) to (8).

TWIN CARBURETTERS

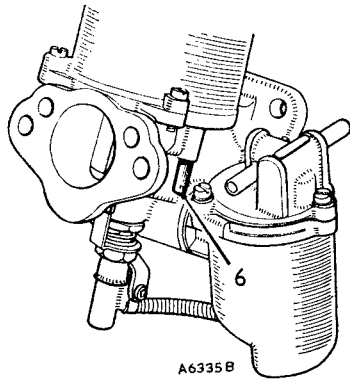

- (4) With the engine stopped, check that the piston falls freely onto the bridge, indicated by a distinct metallic click, when the lifting pin (6) is released. If not refer to 'CARBURETTER SERVICING'.

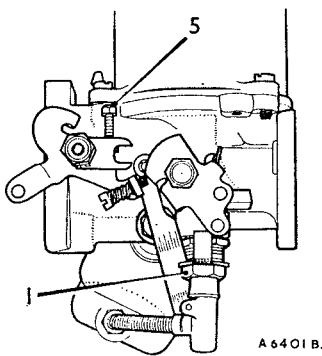

- (5) Turn the jet adjusting nut (1) to cover the full range of adjustment available within the limits of the restrictor, selecting the setting where maximum speed is recorded on the tachometer consistent with smooth running.
- (6) Readjust the throttle adjusting screw (5) to give the correct idling speed if necessary.

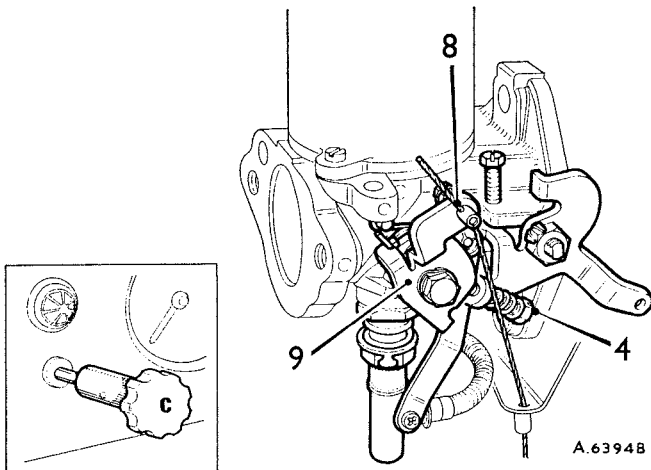

- (7) Check, and if necessary adjust, the mixture control wire (8) to give a free movement of approximately $\frac{1}{8}$ -in. before it starts to pull on the jet lever (9).
- (8) Pull the mixture control knob until the linkage is about to move the carburettor jet and adjust the fast-idle screw (4) to give the engine fast-idle speed (Tachometer) given in 'TUNING DATA'.

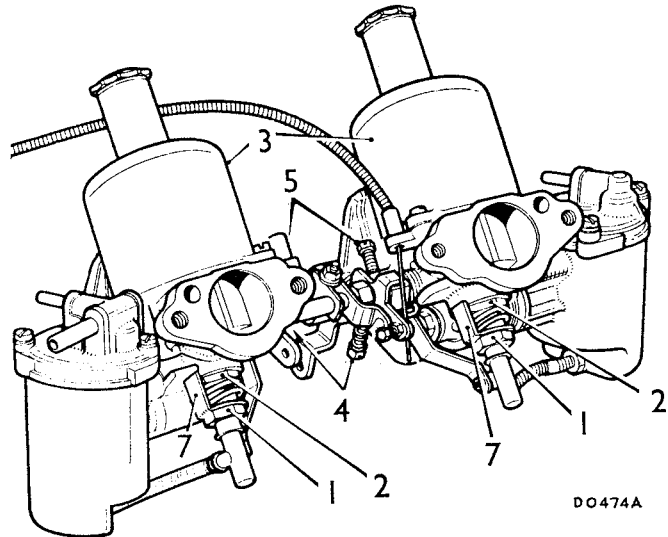

A twin-carburettor installation

- | | |
|-----------------------------|--------------------------------|
| 1. Jet adjusting nuts. | 4. Fast-idle adjusting screws. |
| 2. Jet locking nuts. | 5. Throttle adjusting screws. |
| 3. Piston/suction chambers. | 7. Jet adjustment restrictors. |

NOTE.—In no case should the jet adjustment restrictor be removed or repositioned. Only mixture adjustments within the limits of the restrictor are available for tuning. Balancing of twin carburetters must only be carried out with the use of an approved balancing meter. If satisfactory adjustment or balancing is not obtainable within the limits of the jet adjustment restrictor, refer to 'CARBURETTER SERVICING'.

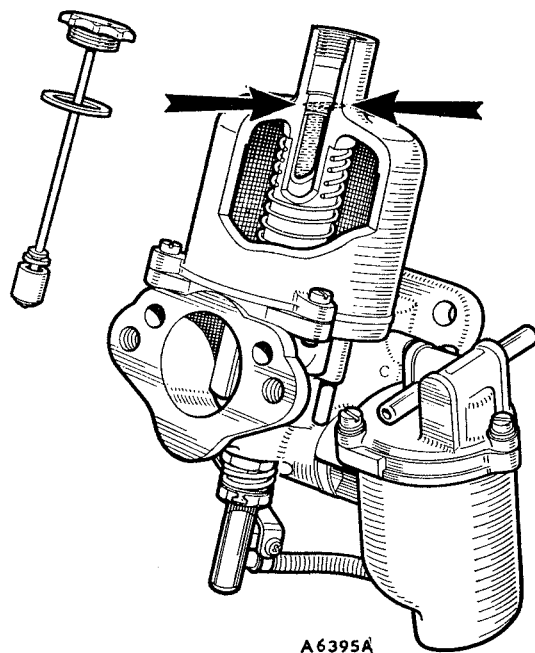

- (1) Top up the piston damper with the recommended engine oil until the level is $\frac{1}{2}$ -in. above the top of the hollow piston rod.

CARBURETTERS

NOTE.—On dust-proofed carburetters, identified by a transverse hole drilled in the neck of the suction chambers and no vent hole in the damper cap, the oil level must be $\frac{1}{2}$ -in. below the top of the hollow piston rod.

- (2) Check the throttle control action for signs of sticking.
- (3) Check the idling speed (Tachometer) against the figure given in 'TUNING DATA'.
 - (a) If the reading is correct and the engine runs smoothly, proceed with operations (11) to (17).
 - (b) If the reading is not correct, carry out operations (4) to (17).

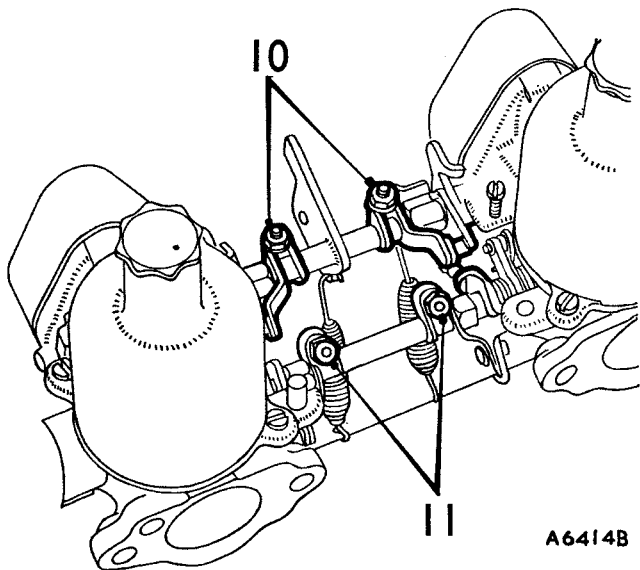

A6414B

- (4) Stop the engine and remove the air cleaners.
- (5) Slacken both of the clamping bolts (10) on the throttle spindle interconnections.
- (6) Disconnect the jet control interconnection by slackening the clamping bolts (11).

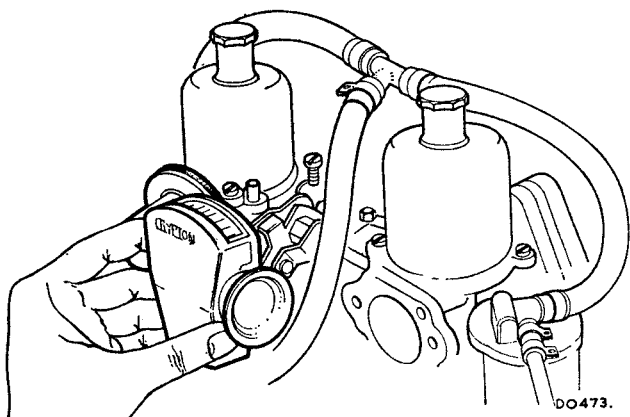

DO473.

- (7) Restart the engine and adjust the throttle adjusting screws on both carburetters to give the correct idling speed as registered by the tachometer.
- (8) Using an approved balancing meter in accordance with the maker's instructions, balance the carburetters by altering the throttle adjusting screws; the idling speed obtained during this operation must be as given in 'TUNING DATA'.

- (a) If after this operation the balance is satisfactory and consistent with smooth running at the correct idle speed, proceed with operations (14) to (17).
- (b) If correct balance cannot be obtained, check the intake system for leaks (i.e. brake servos, engine emission control equipment); if still unsatisfactory, refer to 'CARBURETTER SERVICING'.
- (c) If with the carburetters correctly balanced the idling is still erratic, carry out operations (9) to (17).

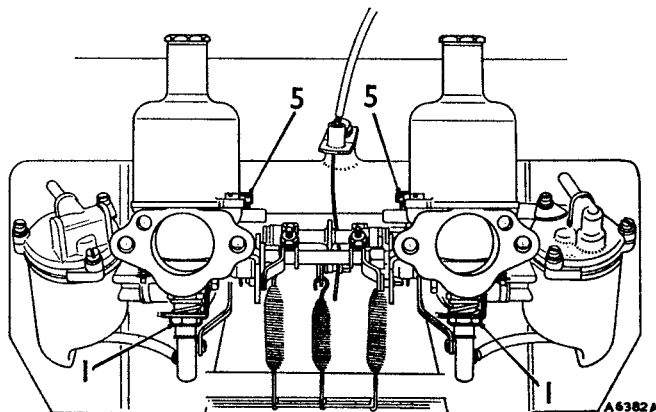

A6382A

- (9) Turn the jet adjusting nut (1) on both carburetters to cover the full range of adjustment available within the limits of the restrictor, selecting the setting where maximum speed is recorded on the tachometer consistent with smooth running.
- (10) Readjust the throttle adjusting screws (5) to give the correct idling speed (see 'TUNING DATA') if necessary, ensuring that both carburetters are adjusted by an equal amount.

If the correct idling speed consistent with smooth running cannot be obtained, refer to 'CARBURETTER SERVICING'.

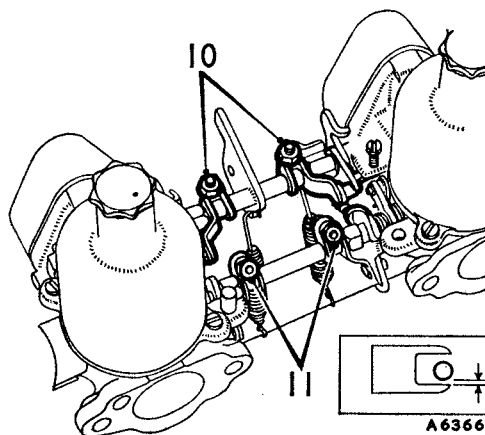

A6366E

- (11) Set the throttle interconnection clamping levers (10) so that the link pin is $\cdot 012$ in. away from the lower edge of the fork (see inset). Tighten the clamp bolts ensuring that there is approximately $\frac{1}{2}$ in. end-float on the interconnection rod.

CARBURETTERS

Dismantling

Carburetters—all types

- (1) Thoroughly clean the outside of the carburetter.
- (2) Mark the relative position (12) of the suction chamber (3) and the carburetter body (13).
- (3) Remove the damper (14) and its washer (15). Unscrew the chamber retaining screws (16).
- (4) Lift off the chamber in the direction of arrow (17) without tilting.
- (5) Remove the piston spring (18).
- (6) Carefully lift out the piston assembly (19) and empty the damper oil from the piston rod (20).

Carburetters—fixed needle type

- (7) Remove the needle locking screw (21) and withdraw the needle (22). If it cannot easily be removed, tap the needle inwards first and then pull outwards. Do not bend the needle.

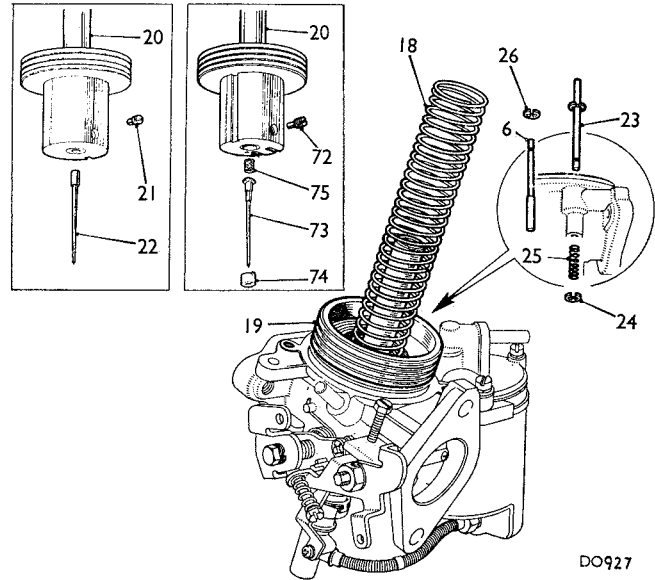

DO927

Carburetters—spring-loaded needle type

- (8) Remove the guide locking screw (72), withdraw the needle assembly (73), needle support guide (74) and spring (75), taking care not to bend the needle.
- (9) Withdraw the needle from the guide and remove the spring from the needle assembly.

Carburetters—all types

- (10) If a piston lifting pin (23) with an external spring is fitted, remove the spring retaining circlip (24) and spring (25), then push the lifting pin upwards to remove it from its guide. With the concealed spring type (6) press the pin upwards, detach the circlip (26) from its upper end, and withdraw the pin and spring downwards.
- (11) Support the moulded base of the jet (26) and slacken the screw (27) retaining the jet pick-up link (28).

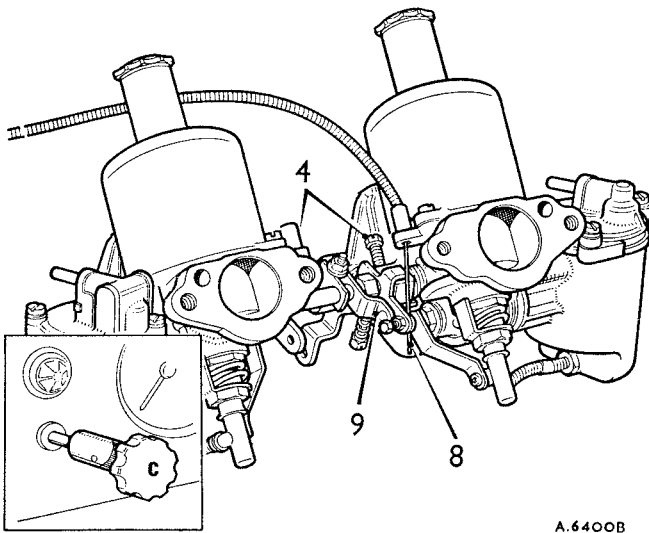

A.6400B

- (12) With both jet levers at their lowest position, set the jet interconnection lever clamp bolts (11) so that both jets commence to move simultaneously.
- (13) Run the engine at 1,500 r.p.m. and, using the balance meter, check that the carburetters are balanced. If they are not balanced, reset the levers, rebalance at idle speed, then recheck at 1,500 r.p.m.
- (14) Check, and if necessary adjust, the mixture control wire (1) to give approximately $\frac{1}{16}$ in. free movement before it starts to pull on the jet levers (9).
- (15) Pull the mixture control knob until the linkage is about to move the carburetter jets.
- (16) Using the carburetter balancing meter to ensure equal adjustment, turn the fast idle adjusting screws (4) to give the correct fast idling speed (see 'TUNING DATA').
- (17) Refit the air cleaners.

Section 4-B

CARBURETTER SERVICING

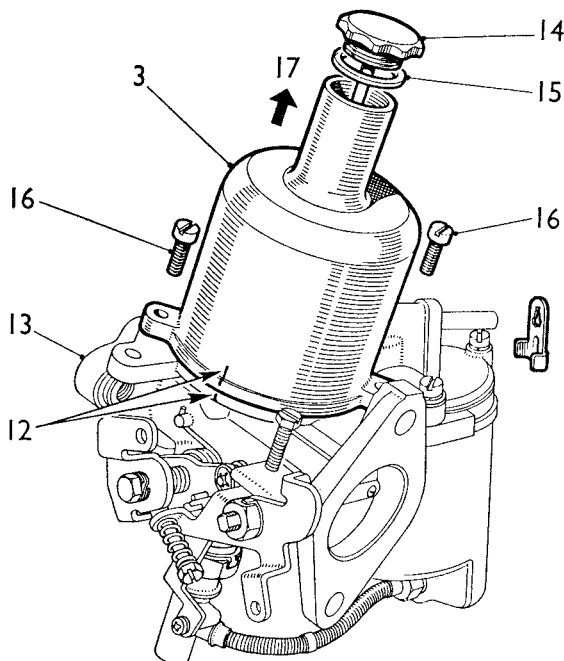

A6699B

CARBURETTERS

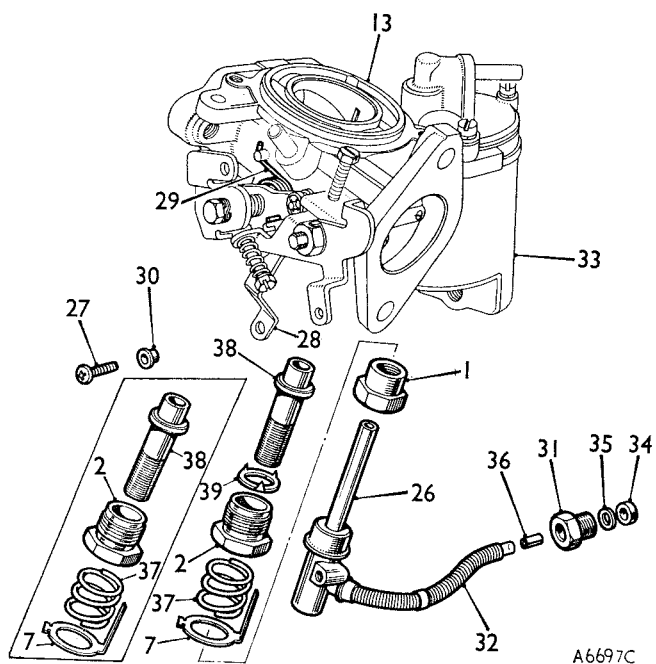

A6697C

- (12) Relieve the tension of the pick-up lever return spring (29) from the screw and remove screw and brass bush (30) (when fitted).
- (13) Unscrew the brass sleeve nut (31) retaining the flexible jet tube (32) to the float-chamber (33) and withdraw the jet assembly (26) from the carburetor body (13). Note the gland (34), washer (35), and ferrule (36) at the end of the jet tube.
- (14) Bend back the small tag on the restrictor (7) to clear the jet adjusting nut, and remove the jet adjusting nut (1), restrictor (7), and spring (37). Unscrew the jet locking nut (2) and detach the nut

and jet bearing (38). Withdraw the bearing from the nut, noting, on fixed needle carburetors only, the locking washer (39) under the shoulder of the bearing.

- (15) Note the location points (see inset, 40) of the two ends of the pick-up lever return spring (41). Unscrew the lever pivot bolt (42) together with its double-coil spring washer (43), or spacer (44). Detach the lever assembly (9) and return spring.
- (16) Note the location (see inset, 45) of the two ends of the cam lever spring (46) and push out the pivot bolt tube (47) (or tubes), taking care not to lose the spring. Lift off the cam lever (48), noting the skid washer (49) between the two levers.

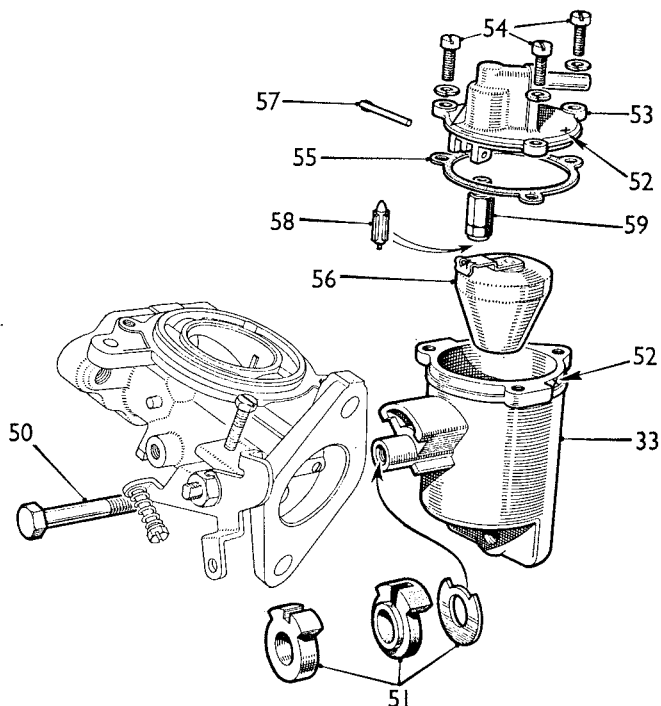

A6695B

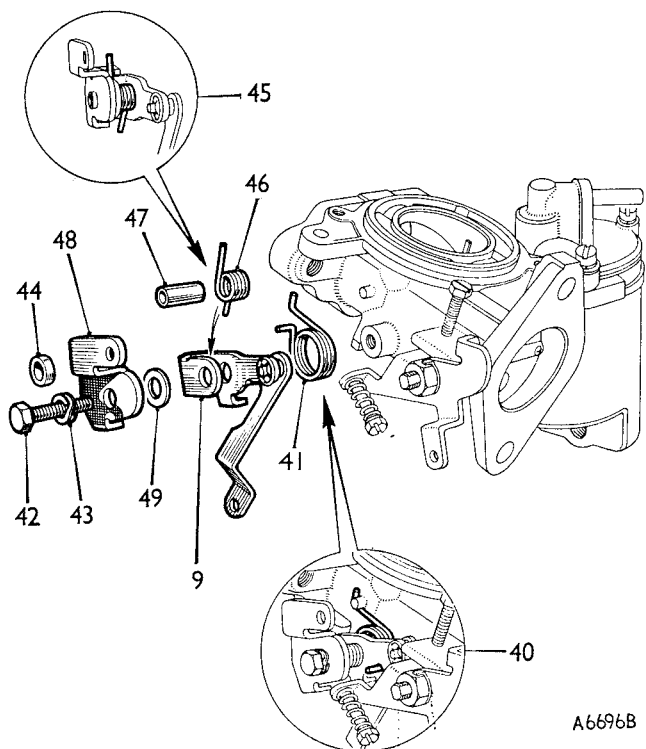

A6696B

- (17) Slacken and remove the bolt (50) retaining the float-chamber (33) to the carburetor body. Note the component sequence of the flexibly mounted chambers (33) and (51).
- (18) Mark (52) the location of the float-chamber lid (53). Unscrew the lid retaining screws (54) and detach the lid and its gasket (55) complete with float assembly (56).
- (19) Push out the float hinge pin (57) from the end opposite its serrations and detach the float.
- (20) Extract the float needle (58) from its seating (59) and unscrew the seating from the lid, using a wrench .338 in. across the flats. Do not distort the seating.
- (21) Close the throttle and mark (60) the relative positions of the throttle disc (61) and the carburetor flange (62). **Do not mark the throttle disc in the vicinity of the limit valve (63).**

- (22) Unscrew the two disc retaining screws (64). Open the throttle and ease out the disc from its slot in the throttle spindle (65). The disc is oval and will jam if care is not taken; store the disc in a safe place until required for reassembly.
- (23) Tap back the tabs of the tab washer (66) securing the spindle nut (67). Note the location of the lever arm (68) in relation to the spindle and carburettor body; remove the nut and detach the arm.

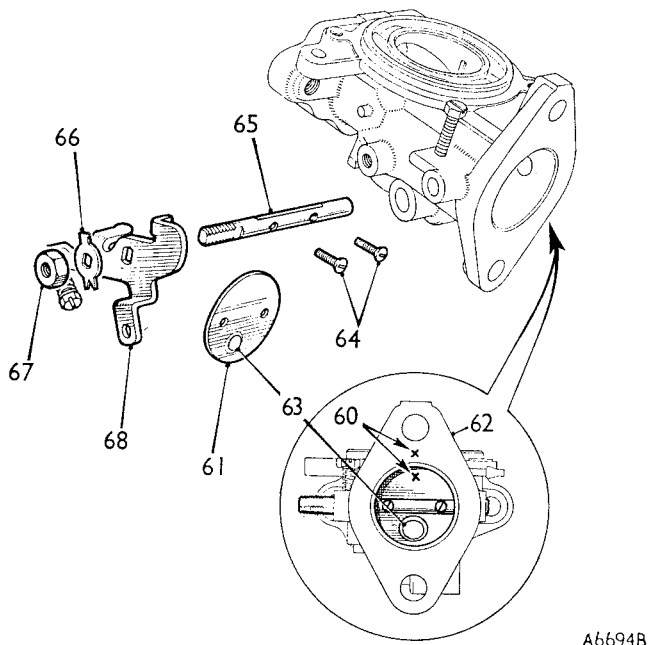

A6694B

Reassembling

Carburettors—all types

NOTE.—Before reassembling, examine all components for wear and damage. Renew unserviceable components, ensuring that only parts to the correct specification (see ‘TUNING DATA’) are used.

- (1) Examine the throttle spindle and its bearings in the carburettor body. Check for excessive play. Renew parts as necessary.
- (2) Refit the spindle to the body. Assemble the operating lever with tab washer and spindle nut, to the spindle. Ensure that when the stop on the lever is against the abutment on the carburettor body (i.e. throttle closed position) the countersunk ends of the holes in the spindle face outwards. Tighten the spindle nut and lock with the tab washer.
- (3) Insert the throttle disc in the slot in the spindle in its original position as marked. Manoeuvre the disc in its slot until the throttle can be closed, snap the throttle open and shut to centralize it in the bore of the carburettor, taking care not to damage the throttle limit valve. When assembled, the valve must be positioned at the bottom of the disc with the head of the valve towards the engine. Fit two new disc retaining screws but do not fully tighten. Check visually that the disc closes fully, and adjust

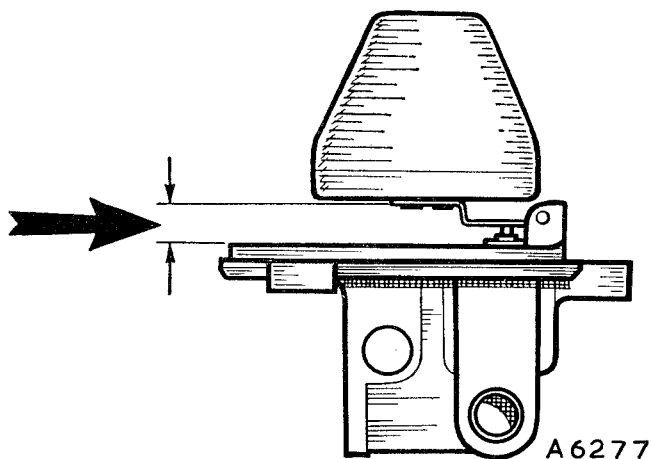

its position as necessary. With the throttle closed there must be clearance between the throttle lever and the carburettor body. Tighten the screws fully and spread their split ends just enough to prevent turning.

- (4) Examine the float needle and seating for damage. Check that the spring-loaded plunger in the end of the plastic-bodied needle operates freely.
- (5) Screw the seating into the float-chamber carefully. Do not overtighten. Replace the needle in the seating, coned end first. Test the assembly for leakage with air pressure.
- (6) Refit the float and lever to the lid and insert the hinge pin and invert the float-chamber lid. With the needle valve held in the shut-off position by the weight of the float only, there should be a $\frac{1}{8}$ to $\frac{3}{16}$ in. gap (arrowed) between the float lever and the rim of the float-chamber lid.
- (7) Examine the lid gasket for re-use. Assemble the gasket on the lid and refit the lid to the float-chamber in the position marked on dismantling. Tighten the securing screws evenly.
- (8) Refit the float-chamber assembly to the carburettor body and tighten the retaining bolt fully, making sure that the registers on the body and the chamber engage correctly.
- (9) Refit the piston lifting pin, spring and circlip.
- (10) Examine the piston assembly for damage on the piston rod and the outside surface of the piston. The piston assembly must be scrupulously clean. Use gasoline or methylated spirit (denatured alcohol) as a cleaning agent. **Do not use abrasives.** Wipe dry, using a clean dry cloth.
- (11) Clean inside the suction chamber and piston rod guide using gasoline or methylated spirit (denatured alcohol) and wipe dry. Refit the damper and washer. Temporarily plug the piston transfer holes (69) and fit the piston into the suction chamber. Fit a nut and screw, with a large flat washer under the head of the screw into one of the suction

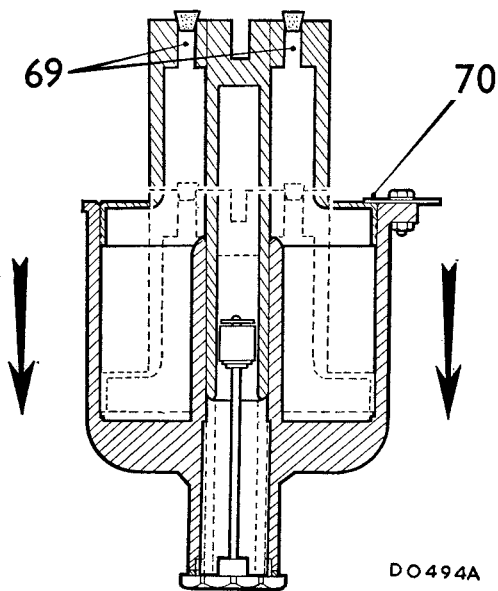

chamber fixing holes, positioning the washer (70) so that it overlaps the suction chamber bore (see illustration). Check that the piston is fully home in the suction chamber and invert the assembly to allow the chamber to fall away from the piston until the piston contacts the flat washer. Check the time taken for the suction chamber to fall the full extent of the piston travel. For HS2-type carburetors of $1\frac{1}{4}$ in. bore the time taken should be 3 to 5 seconds, and for larger carburetors 5 to 7 seconds. If these times are exceeded check the piston and suction chamber for cleanliness and mechanical damage. If after rechecking the time taken is still not within these limits, renew the suction chamber and piston assembly.

Carburetors—fixed needle type

- (12) Refit the needle to the piston assembly (19). The lower edge of the needle shoulder (22) must be level with the bottom face of the piston rod (20).
- (13) Fit a new needle locking screw (21) and tighten. Invert the suction chamber and spin the piston assembly inside it to check for concentricity of the needle.

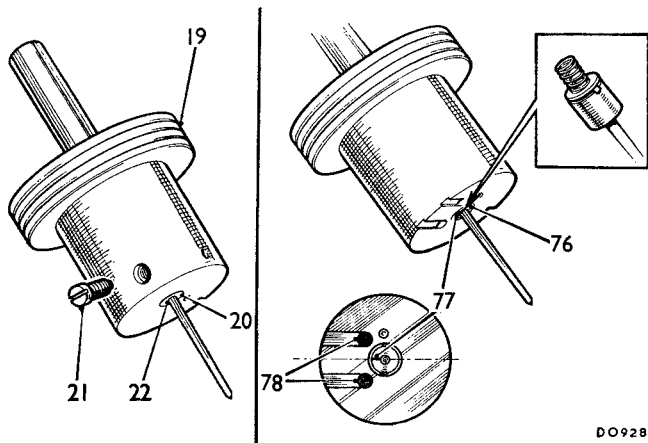

- (14) Check the piston key for security in the carburetor body. Refit the piston assembly to the body and replace the piston spring over the piston rod.
- (15) Fit the suction chamber and retaining screws, taking care not to wind up the spring; tighten the securing screws evenly.
- (16) Refit the jet bearing, a new locking washer, and the locking nut; do not tighten the nut.
- (17) Centralize the jet as follows:
 - (a) Enter the end of the nylon feed tube into the base of the float-chamber, without the gland or washer fitted. Loosely secure with the retaining nut.
 - (b) Feed the jet into the jet bearing; do not fit the jet nut spring, jet adjustment restrictor, or adjusting nut at this stage.
 - (c) With the carburetor positioned with its inlet flange downwards, insert the piston loading tool into damper tube at the top of the suction chamber and screw in until fully home. Screw the tool back until the arrow, on the tool, points towards the inlet flange of the carburetor. **The tool and carburetor must remain in this position throughout the centering operation.**
 - (d) With the piston at the bottom of its travel (on the bridge), and the jet hard up against the jet bearing, slowly tighten the jet locking nut. During the tightening process ensure that the jet is not binding in its bearing when drawn in and out. If any tightness between the jet and bearing is detected, the jet locking nut must be slackened and the process repeated.
 - (e) Remove the jet loading tool.

- (18) Withdraw the jet and tube; refit the spring, restrictor and jet adjusting nut. Fit the gland and washer to the flexible tube. The end of the tube should project a minimum of $\frac{1}{8}$ in. beyond the gland. Refit the jet and tube. Tighten the sleeve nut until the neoprene gland is compressed. Overtightening can cause leakage.

Carburetors—spring-loaded needle type

- (19) Refit the jet bearing, fit and tighten the jet locking nut. No jet centering is required with the spring-loaded type jet needle.
- (20) Fit the jet nut spring and adjustment restrictor. Fit the jet adjusting nut and screw it up as far as possible.
- (21) Feed the jet into the jet bearing. Fit the sleeve nut, washer and gland to the end of the flexible tube. The tube must project a minimum of $\frac{1}{8}$ in. (4.8 mm.) beyond the gland. Tighten the sleeve nut until the gland is compressed. Overtightening can cause leakage.

CARBURETTERS

- (22) Refit the spring to the jet needle assembly, ensuring that it locates completely in the groove of the needle support.
- (23) **IMPORTANT.** Spring-loaded needles are supplied complete with shouldered spring seats; no attempt should be made to alter the position of the spring seat or convert a fixed-type needle to spring-loaded application. The raised 'pip' formed in the needle guide ensures that the needle is correctly centralized. Under no circumstances must the 'pip' be removed or repositioned.

Fit the needle assembly into its guide and fit the assembly into the piston. The lower edge of the guide (76) must be flush with the face of the piston and the guide positioned so that the etched locating mark (77) on its lower face is adjacent to and in line with the midway point between the two piston transfer holes as illustrated.

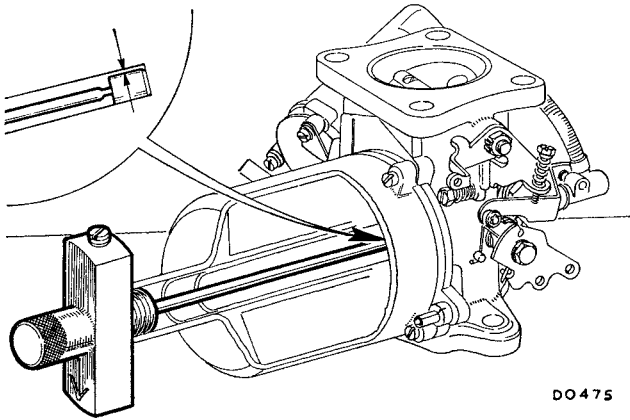

Alternative needle guides have a flat machined on the guide which must be positioned so that the guide locking screw tightens down onto the flat. If the guide is incorrectly positioned so that the locking screw has not tightened down on the flat, the head of the screw will protrude from the piston.

- (24) Fit a new guide locking screw. **NOTE.**—Guide locking screws for spring-loaded needles are shorter than the needle locking screws used with fixed needles.
- (25) Check the piston key for security in the carburettor body. Refit the piston assembly to the body and place the piston spring over the piston rod.
- (26) Fit the suction chamber and retaining screws, taking care not to wind up the spring; tighten the securing screws evenly.

Carburetters—all types

- (27) Refit the damper and washer.
- (28) Reassemble the pick-up lever, cam lever, cam lever spring, skid washer, and pivot bolt tube or tubes in the positions noted on dismantling.
- (29) Place the pick-up lever return spring in position over its boss and secure the lever assembly to the carburettor body with the pivot bolt. Ensure that the double-coil spring washer or spacer fits over the projecting end of the pivot bolt tube.
- (30) Register the angled end of the return spring in the groove in the pick-up lever, and hook the other end of the spring around the moulded peg on the carburettor body.
- (31) Fit the brass ferrule to the hole in the end of the pick-up link. Relieve the tension of the return spring and fit the link to the jet with its retaining screw. When finally tightening the screw, support the moulded end of the jet.
- (32) Without removing the suction chamber, screw the jet adjusting nut until the top face of the jet is flush with the bridge of the carburettor.
- (33) Turn down the jet adjusting nut to the initial jet setting given in 'TUNING DATA'.
- (34) Refit the carburettor(s) to the engine, following the instructions given in the relevant vehicle Workshop Manual.

Tune the carburetters in accordance with the instructions given in 'CARBURETTER TUNING —COMPLETE'.

CARBURETTERS

Section 4-C

CARBURETTER TUNING—COMPLETE

The following instructions apply only to new carburetters or carburetters which have been serviced as described in 'CARBURETTER SERVICING'.

The tuning must be carried out with the engine emission control equipment connected and operating.

SINGLE CARBURETTERS

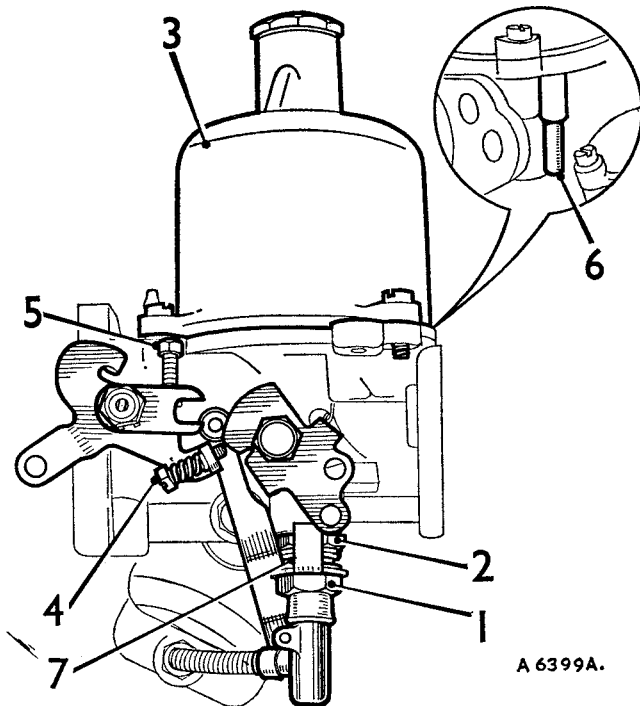

The type HS carburettor

- | | |
|-------------------------------|-------------------------------|
| 1. Jet adjusting nut. | 4. Fast-idle adjusting screw. |
| 2. Jet locking nut. | 5. Throttle adjusting screw. |
| 3. Piston suction chamber. | 6. Piston lifting pin. |
| 7. Jet adjustment restrictor. | |

Initial setting

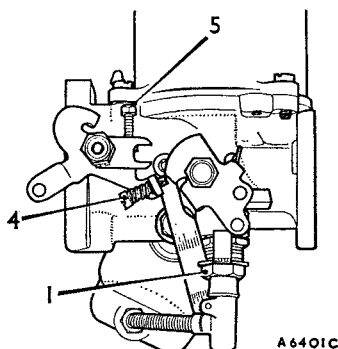

- (1) Disconnect the mixture control (choke) wire if fitted.
- (2) Unscrew the fast-idle screw (4) until it is well clear of the cam.
- (3) Unscrew the throttle adjusting screw (5) until it is just clear of its stop and the throttle is closed.

- (4) Set the throttle adjusting screw one full turn open.
- (5) The jet adjusting nut must not be altered at this stage as it will be initially set to a datum setting at the factory or during the carburettor servicing procedure.

Tuning conditions

To ensure that the engine temperature and mixture requirements are stabilized, tuning must be carried out in accordance with the following setting cycle.

- (1) Connect the tachometer and an approved exhaust gas analyser in accordance with the instrument-maker's instructions.
- (2) Warm the engine at a fast idle to normal operating temperature preferably with the car standing in an ambient temperature of between 16 and 27° C. (60 to 80° F.). Run the engine for at least five minutes after the thermostat has opened; the thermostat opening point can be detected by the sudden rise in temperature of the radiator header tank.
- (3) Set the engine speed at 2,500 r.p.m., at no load, and run for one minute.
- (4) Tuning operations may now be commenced and must be carried out in the shortest possible time. If the time for settings exceeds a three-minute period, open the throttle and run the engine at 2,500 r.p.m. for one minute then resume tuning. Repeat this clearing operation if further periods of three minutes are exceeded.

Tuning procedure

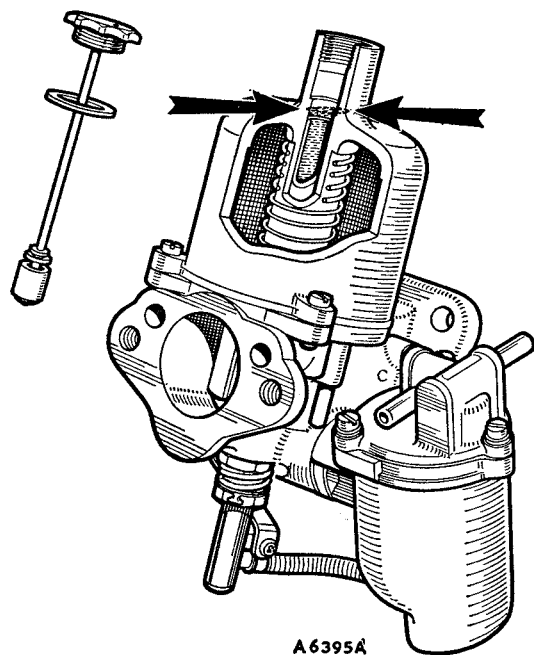

- (1) Top up the piston damper with the recommended engine oil until the level is $\frac{1}{2}$ in. above the top of the hollow piston rod.

NOTE.—On dust-proofed carburettors, identified by a transverse hole drilled in the neck of the suction chambers and no vent hole in the damper cap, the oil level must be $\frac{1}{2}$ in. below the top of the hollow piston rod.

- (2) Warm up the engine as described in 'Tuning conditions'.

Turn the throttle adjusting screw until the idling speed given in 'TUNING DATA' is obtained.

- (3) During the following procedure, just before the readings of the tachometer and exhaust gas analyser are taken gently tap the neck of the suction chamber with a light non-metallic instrument (e.g. a screwdriver handle).

Turn the jet adjusting nut up to weaken, down to richen, until the fastest speed is recorded on the tachometer. Turn the jet adjusting nut very slowly up (weaken) until the engine speed just commences to fall, then turn the nut one flat down (rich). Check the idling speed against the figure given in 'TUNING DATA', and adjust if necessary using the throttle adjusting screw.

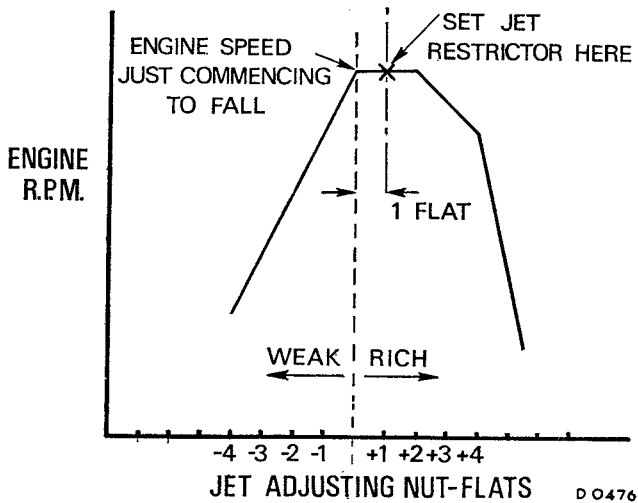

- (4) Using the exhaust gas analyser, check that the percentage CO reading is within the limits given in 'TUNING DATA'.

If the reading falls outside the limits given, reset the jet adjusting nut by the minimum amount necessary to bring the reading just within the limits. If an adjustment exceeding two flats is required to achieve this the test equipment should be checked for correct calibration.

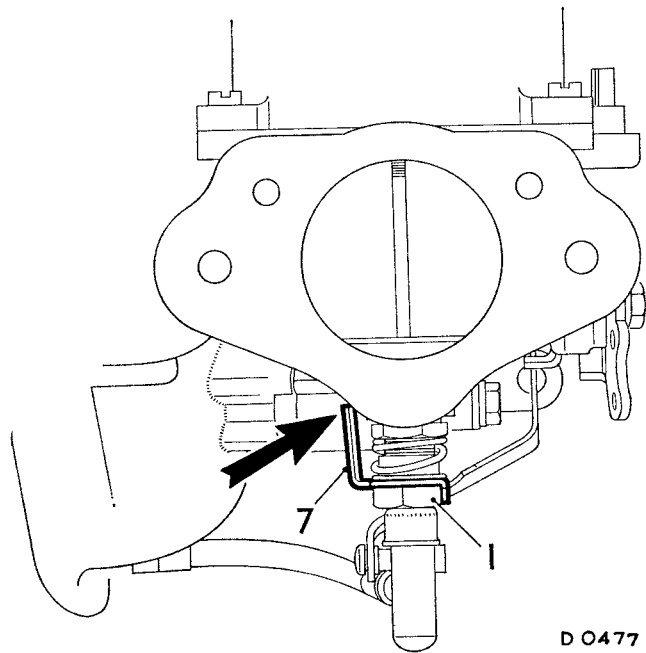

- (5) Hold the jet adjusting nut (1) to prevent it turning, and rotate the adjustment restrictor (7) round the nut until the vertical tag contacts the carburettor body on the left-hand side when viewed from the air cleaner flange (see illustration). In this position, bend the small tag on the adjustment restrictor down so that the restrictor locks to the nut and will follow its movements.
- (6) Paint the small tag of the jet adjusting nut restrictor and the adjacent flat of the jet nut to identify the locking position.

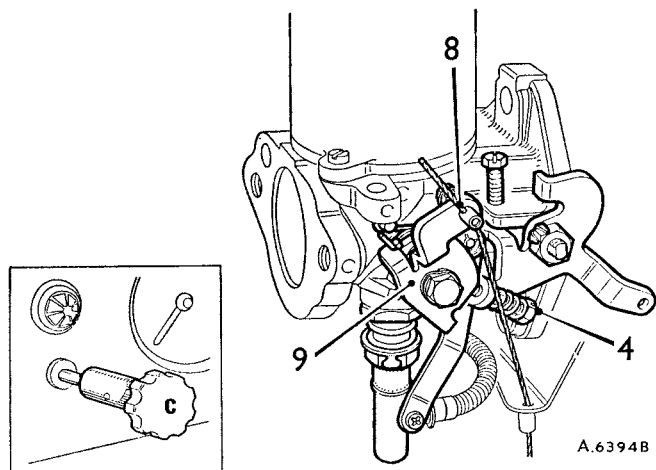

- (7) Reconnect the mixture control wire (8) with approximately $\frac{1}{16}$ in. free movement before it starts to pull on the jet lever (9).
- (8) Pull the mixture control knob until the linkage is about to move the carburettor jet and adjust the fast-idle screw (4) to give the engine fast-idle speed.
- (9) Check and if necessary adjust the throttle damper setting—if fitted (see 'TUNING DATA').

TWIN CARBURETTERS

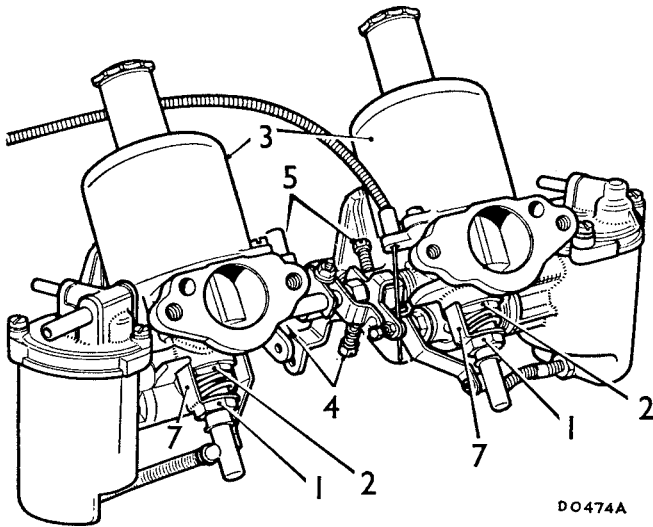

A twin-carburettor installation

- | | |
|-----------------------------|--------------------------------|
| 1. Jet adjusting nuts. | 4. Fast-idle adjusting screws. |
| 2. Jet locking nuts. | 5. Throttle adjusting screws. |
| 3. Piston/suction chambers. | 7. Jet adjustment restrictors. |

Initial settings

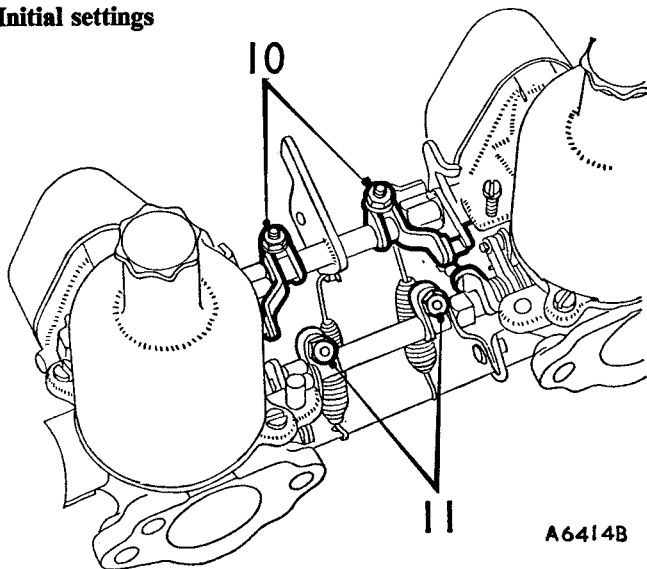

- (1) Slacken both clamping bolts (10) on the throttle spindle interconnections.
- (2) Disconnect the jet control interconnection by slackening the clamping bolts (11).
- (3) Disconnect the mixture control wire if fitted.

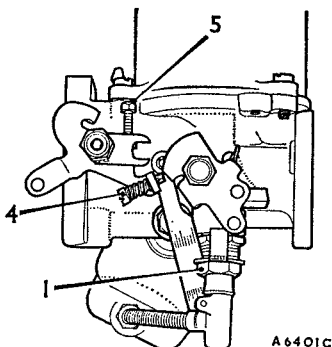

- (4) Unscrew the fast-idle screw (4) on both carburetors until they are well clear of the cams.
- (5) Unscrew the throttle adjusting screw (5) on both carburetors until they are just clear of their stops and the throttles are closed.
- (6) Set the throttle adjustment screws on both carburetors half a turn open.
- (7) The jet adjusting nuts must not be altered at this stage as they will be initially set to a datum setting either at the factory or during the carburetter servicing procedure.

Tuning conditions

To ensure that the engine temperature and mixture requirements are stabilized, tuning must be carried out in accordance with the following setting cycle.

- (1) Connect a tachometer and an approved exhaust gas analyser in accordance with the instrument-maker's instructions.
- (2) Warm the engine at a fast idle to normal operating temperature preferably with the car standing in an ambient temperature of between 16 and 27° C. (60 to 80° F.). Run the engine for at least five minutes after the thermostat has opened; the thermostat opening point can be detected by the sudden rise in temperature of the radiator header tank.
- (3) Set the engine speed at 2,500 r.p.m., at no load, and run for one minute.
- (4) Tuning operations may now be commenced and must be carried out in the shortest possible time. If the time for settings exceeds a three-minute period, open the throttle and run the engine at 2,500 r.p.m. for one minute then resume tuning. Repeat this clearing operation if further periods of three minutes are exceeded.

Tuning procedure

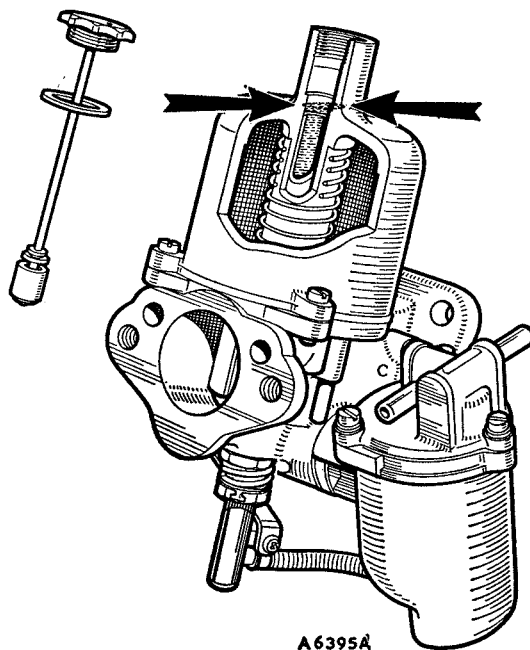

CARBURETTERS

- (1) Top up the piston damper with the recommended engine oil until the level is $\frac{1}{2}$ in. above the top of the hollow piston rod.

NOTE.—On dust-proofed carburetters, identified by a transverse hole drilled in the neck of the suction chambers and no vent hole in the damper cap, the oil level must be $\frac{1}{2}$ in. below the top of the hollow piston rod.

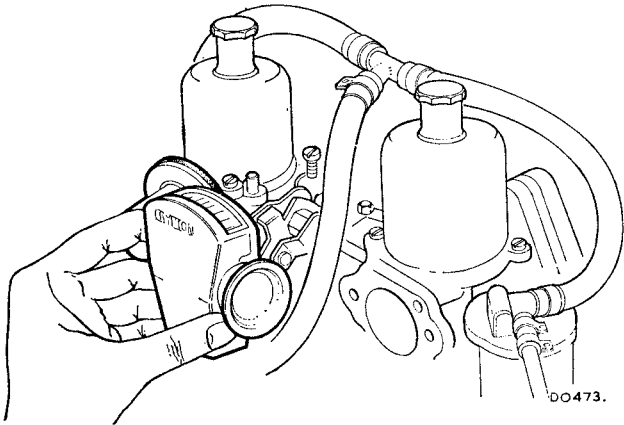

- (2) Warm up the engine as described in 'TUNING CONDITIONS.'
- (3) Turn the throttle adjusting screw on both carburetters until the idling speed given in 'TUNING DATA' is obtained.
- (4) Using an approved balancing meter in accordance with the maker's instructions, balance the carburetters by altering the throttle adjusting screws; the idling speed obtained during this operation must be as given in 'TUNING DATA'.

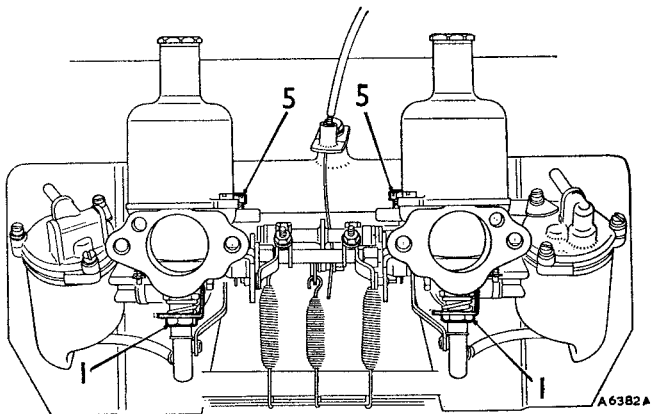

- (5) During the following procedure, just before the readings of the tachometer and exhaust gas analyser are taken, gently tap the neck of each suction chamber with a light non-metallic instrument (e.g. a screwdriver handle).

Turn the jet adjusting nut (1) on both carburetters up to weaken, down to richen, the same amount until the fastest speed is recorded on the tachometer.

Turn both adjusting nuts very slowly up (weaken) until the engine speed just commences to fall, then turn both adjusting nuts one flat down (rich).

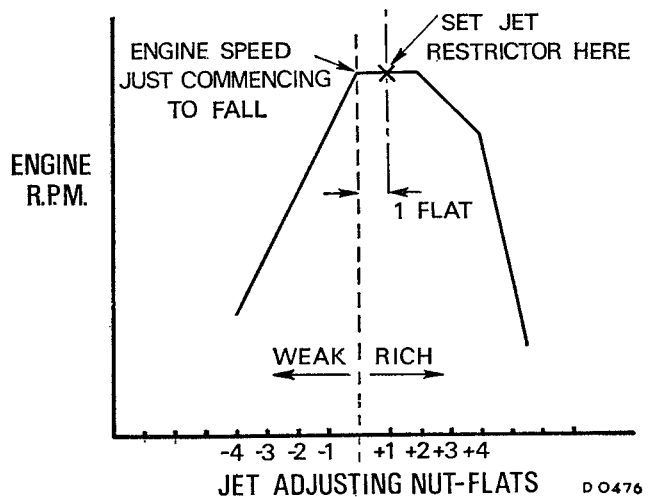

Check the idling speed against the figure given in 'TUNING DATA', and adjust if necessary by altering both throttle adjusting screws, each by the same amount. Using the balancing meter, check that the carburetters are balanced.

- (6) Using the exhaust gas analyser, check that the percentage CO reading is within the limits given in 'TUNING DATA'.

If the reading falls outside the limits given, reset both jet adjusting nuts by the minimum amount necessary to bring the reading just within the limits. If an adjustment exceeding two flats is required to achieve this the test equipment should be checked for correct calibration.

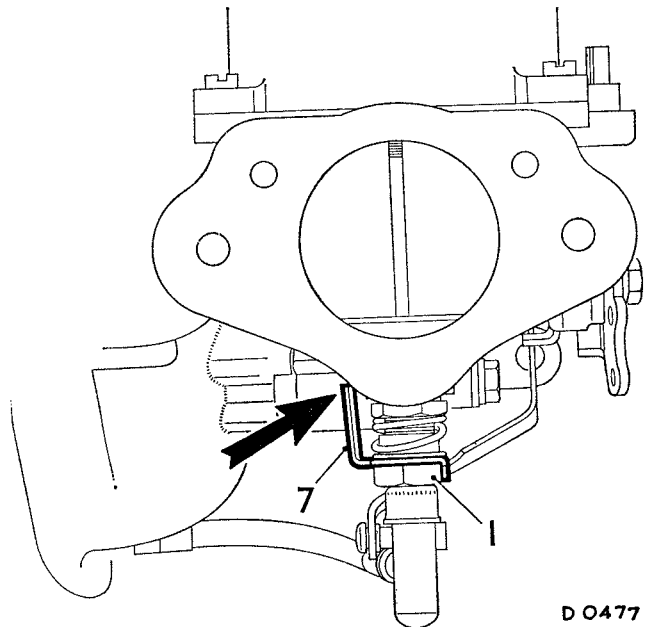

- (7) Hold the jet adjusting nut (1) on each carburettor, to prevent it turning, and rotate the adjustment restrictor (7) round the nut until the vertical tag contacts the carburettor body on the left-hand side when viewed from the air cleaner flange (see illustration). In this position, bend the small tag on the adjustment restrictor down so that the restrictor locks to the nut and will follow its movements.

CARBURETTERS

- (8) Paint the small tag of the jet adjusting nut restrictor and the adjacent flat of the jet nut to identify the locking position.
- (9) Set the throttle interconnection clamping levers (10) in accordance with the instructions given in the relevant vehicle Workshop Manual, so that a clearance exists between the link pin and the lower edge of the fork (see inset). Tighten the clamp bolts ensuring that there is approximately $\frac{1}{32}$ in. end float on the interconnection rod.

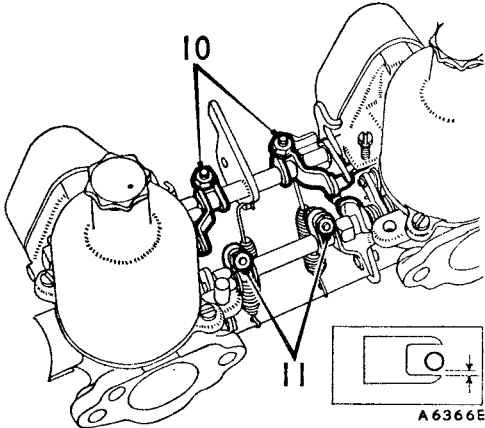

- (10) With both jet levers at their lowest position, set the jet interconnection lever clamp bolts (11) so that both jets commence to move simultaneously.

Run the engine at 1,500 r.p.m. and, using the balance meter, check that the carburetters are balanced.

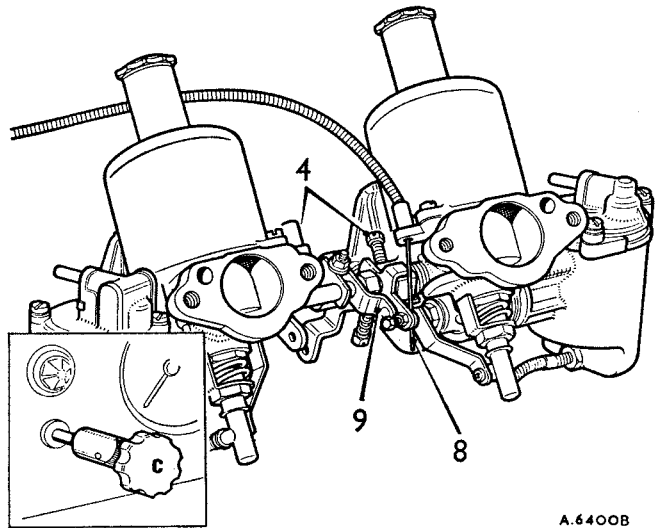

- (11) Reconnect the mixture control wire (8) with approximately $\frac{1}{16}$ in. free movement before it starts to pull on the jet levers (9).
- (12) Pull the mixture control knob until the linkage is about to move the carburetter jets.
- (13) Using the carburetter balancing meter to ensure equal adjustment, turn the fast-idle adjusting screws (4) to give the correct fast idling speed (see 'TUNING DATA').
- (14) Refit the air cleaners.

Section 4-D

TYPE HIF CARBURETTERS—TUNING (Fitted to MGB from 1972 Model Year)

General

The carburetters fitted to cars equipped with engine emission control systems are balanced to provide engine performance with pollution control. Under no circumstances may they or their components be interchanged or substituted with normal carburetters.

Tuning must be carried out with the engine emission control equipment connected and operating.

IMPORTANT.—Before servicing or tuning a carburetter in an endeavour to rectify poor engine performance, make sure that the maladjustment or fault is not from another source by checking the following:

- Valve clearance
- Spark plug condition
- Contact breaker (dwell angle)
- Ignition timing and advance
- Presence of air leaks into the induction system

Single and twin carburetters

- (1) Remove the air cleaner(s).
- (2) Check the throttle for correct operation and signs of sticking.
- (3) Unscrew the throttle adjusting screw (both screws on twin carburetters) until it is just clear of the throttle lever, with the throttle closed, then turn the screw clockwise two full turns.
- (4) Raise the piston of each carburetter with the lifting pin and check that it falls freely onto the bridge when the pin is released. If the piston shows any tendency to stick, the carburetter must be serviced.
- (5) Lift and support the piston clear of the bridge so that the jet is visible; if this is not possible due to the installed position of the carburetter, remove the suction piston chamber.
- (6) Turn the jet adjusting screw anti-clockwise until the jet is flush with the bridge or as high as possible without exceeding the bridge height. Ensure that both jets on twin carburetters are in the same relative position to the bridge of their respective carburetters.
- (7) Check that the needle guide(s) is flush with the bottom of the piston groove.
- (8) Turn the jet adjusting screw two turns clockwise (both screws on twin carburetters).
- (9) Turn the fast idle adjusting screw anti-clockwise (both screws on twin carburetters) until it is well clear of the cam.
- (10) Refit the suction piston chamber if it has been removed and, using the lifting pin, check that the piston falls freely onto the bridge.
- (11) Top up the piston damper reservoir(s) with a recommended oil until the level is $\frac{1}{2}$ in. (13 mm.) above the top of the hollow piston rod.

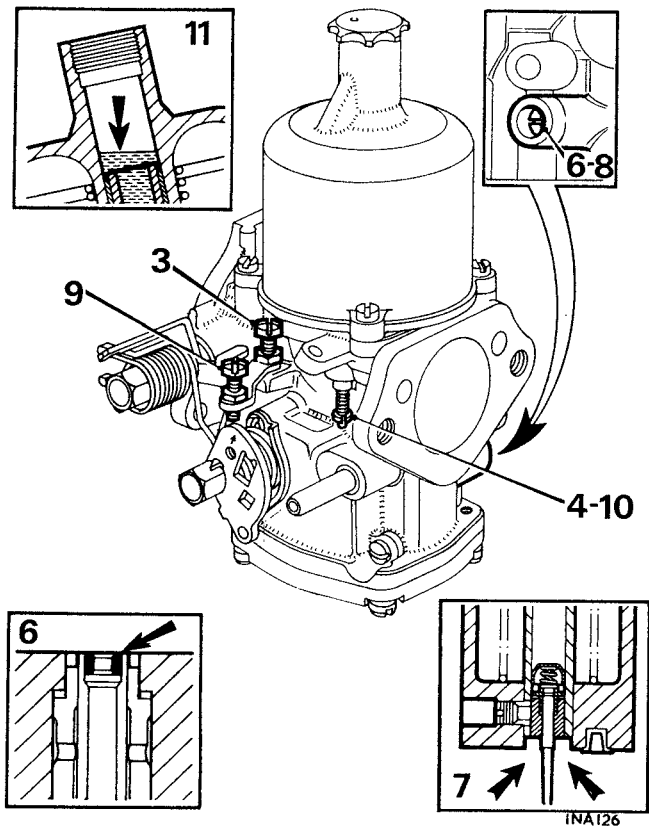

CARBURETTERS

- (12) Connect a reliable tachometer to the engine in accordance with the instrument manufacturer's instructions.
- (13) Start the engine and run it at a fast idle speed until it attains normal running temperature, then run it for a further five minutes.
- (14) Increase the engine speed to 2,500 r.p.m. for thirty seconds.
- (15) Connect an approved exhaust gas analyser to the engine in accordance with the instrument manufacturer's instructions.

NOTE.—Tuning can now commence. If the correct setting cannot be obtained within three minutes, increase the engine speed to 2,500 r.p.m. for thirty seconds and then recommence tuning. Repeat this clearing operation at three-minute intervals until tuning is completed.

Single carburetters

- (16) Adjust the throttle adjusting screw until the correct idle speed (see 'TUNING DATA' and/or Vehicle Emission Control Information Label) is obtained.

NOTE.—During the following procedure, just before the readings of the tachometer and exhaust gas analyser are taken, gently tap the neck of the suction chamber with a light-metallic instrument (e.g. a screwdriver handle).

- (17) Turn the jet adjusting screw, clockwise to enrich or anti-clockwise to weaken, until the fastest speed is indicated on the tachometer; turn the screw anti-clockwise until the engine speed just commences to fall. Turn the screw clockwise very slowly the minimum amount until the maximum speed is regained.
- (18) Check the idle speed, and re-adjust it as necessary with the throttle adjusting screw to obtain the correct setting.
- (19) Using the exhaust gas analyser, check that the percentage CO reading is within the limits given in 'TUNING DATA' and/or Vehicle Emission Control Information Label. If the reading falls outside the limits given, reset the jet adjusting screw by the minimum amount necessary to bring the reading just within the limits. If an adjustment exceeding half a turn of the adjusting screw is required to achieve this, the carburetter must be removed and overhauled.
- (20) With the fast idle cam against its return stop, check that a $\frac{1}{16}$ in. (1.5 mm.) free movement of the mixture control (choke) cable exists before the cable moves the cam.
- (21) Pull out the mixture control (choke) until the arrow marked on the cam is positioned under the fast idle adjusting screw.
- (22) Turn the fast idle adjusting screw clockwise until the correct fast idle speed (see 'TUNING DATA' and/or Vehicle Emission Control Information Label) is obtained.
- (23) Refit the air cleaner.

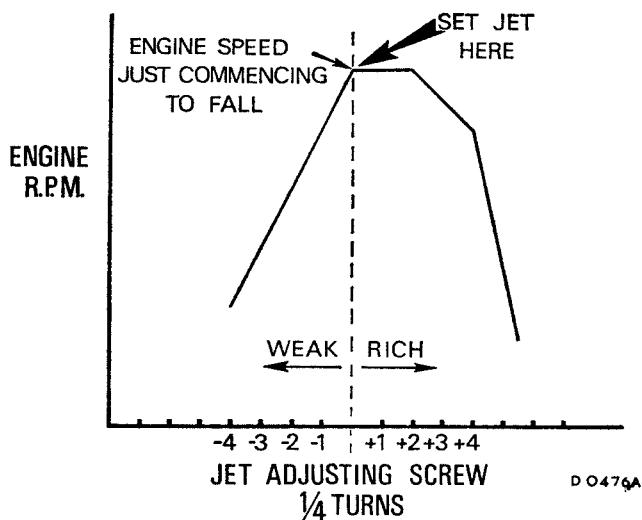
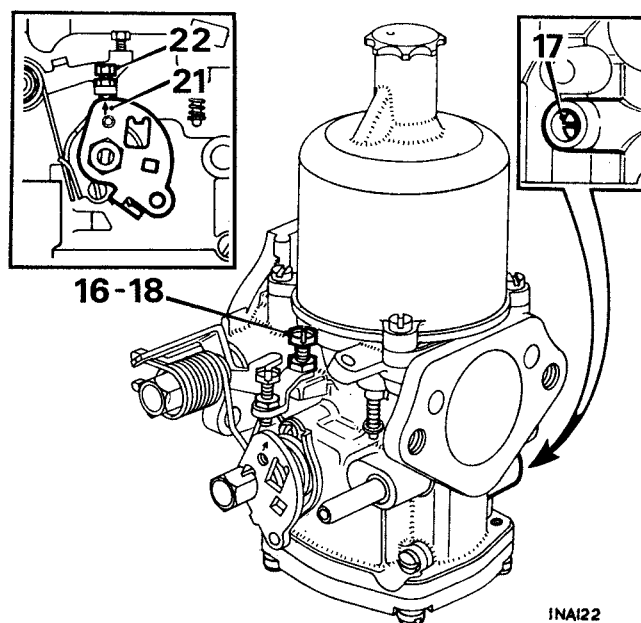

CARBURETTERS

Twin carburetters

- (24) Slacken both clamping bolts on the throttle spindle interconnections.
- (25) Slacken both clamping bolts on the cold start interconnections.

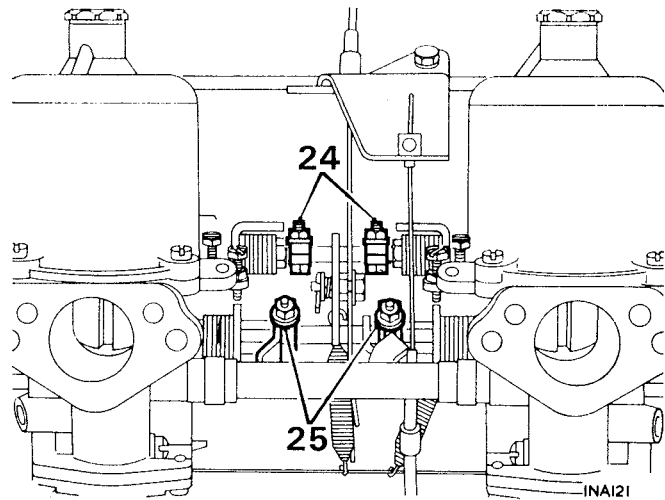

- (26) Using an approved balancing meter in accordance with the maker's instructions, balance the carburetors by altering the throttle adjusting screws until the correct idle speed and balance is achieved.

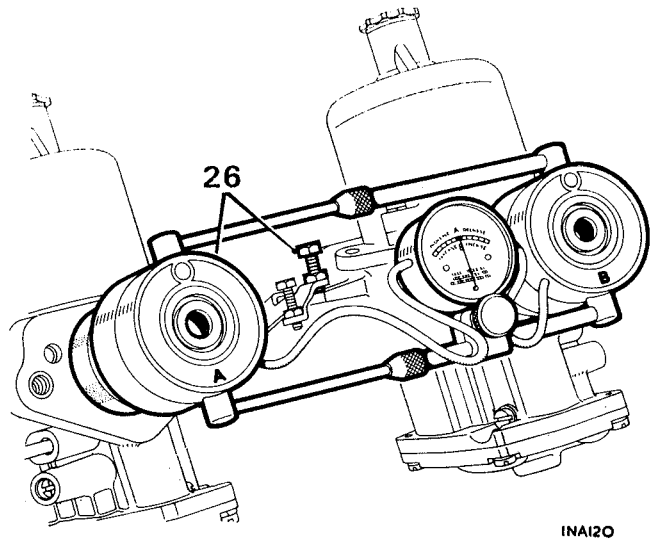

CARBURETTERS

NOTE.—During the following procedure, just before reading the tachometer and exhaust gas analyser, gently tap the neck of each suction chamber with a non-metallic instrument (e.g. a screwdriver handle).

- (27) Turn the jet adjusting screw on both carburetters clockwise to enrich or anti-clockwise to weaken, by the same amount until the fastest speed is registered on the tachometer; turn both screws anti-clockwise until the engine speed just commences to fall. Turn both screws very slowly clockwise by the minimum amount until the maximum speed is regained.
- (28) Using the exhaust gas analyser, check that the percentage CO reading is within the limits given in 'TUNING DATA' and/or Vehicle Emission Control Information Label. If the reading falls outside the limits given, reset both jet adjusting screws by the minimum amount necessary to bring the readings just within the limits. If an adjustment exceeding half a turn is required to achieve this the carburetters must be removed and overhauled.
- (29) Set the throttle interconnection clamping levers, in accordance with the instructions given in the relevant vehicle Workshop Manual, so that a clearance exists between the link pin and the lower edge of the fork. Tighten the clamp bolts, ensuring that there is approximately $\frac{1}{32}$ in. end-float on the interconnection rod.
- (30) Run the engine at 1,500 r.p.m. and check the throttle linkage for correct connection by re-checking the carburetter balance.
- (31) With the fast idle cams of both carburetters against their respective stops, set the cold start interconnections so that both cams begin to move simultaneously.
- (32) With the fast idle cams against their stops check that a $\frac{1}{16}$ in. (1.5 mm.) free movement of the mixture control (choke) cable exists before the cable moves the cams.
- (33) Pull out the mixture control (choke) until the arrow marked on the cam is positioned under the fast idle adjusting screw of each carburetter.
- (34) Using the balancing meter to ensure equal adjustment, turn the fast idle adjusting screws to give the correct fast idle speed (see 'TUNING DATA' and/or Vehicle Emission Control Information Label).
- (35) Refit the air cleaners.

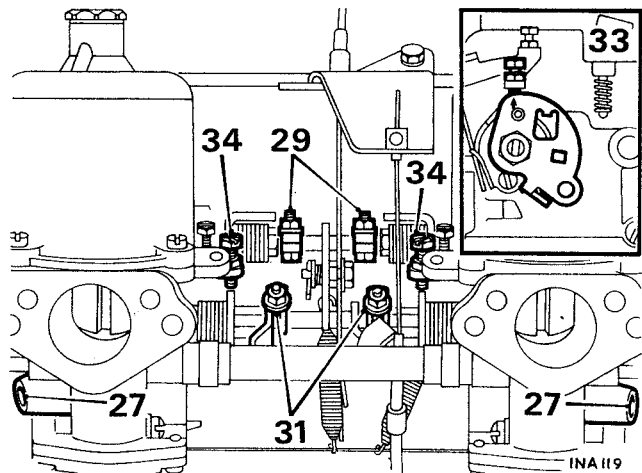
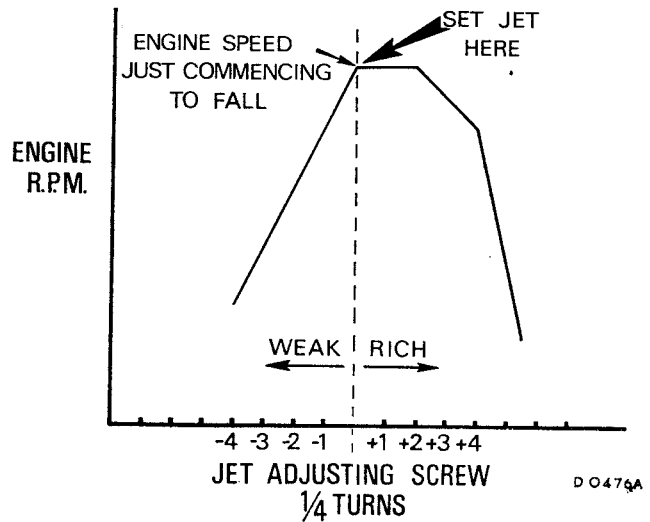

Section 4-E

TYPE HIF CARBURETTORS—OVERHAULING (Fitted to MGB from 1972 Model Year)

Dismantling

- (1) Thoroughly clean the outside of the carburettor.
- (2) Remove the piston damper and its washer.
- (3) Unscrew the suction piston chamber retaining screws and remove the identity tag.
- (4) Lift the chamber vertically from the body without tilting it.
- (5) Remove the piston spring, lift out the piston assembly and empty the oil from the piston rod.
- (6) Unscrew the needle guide locking screw.
- (7) Withdraw the needle, guide and spring.

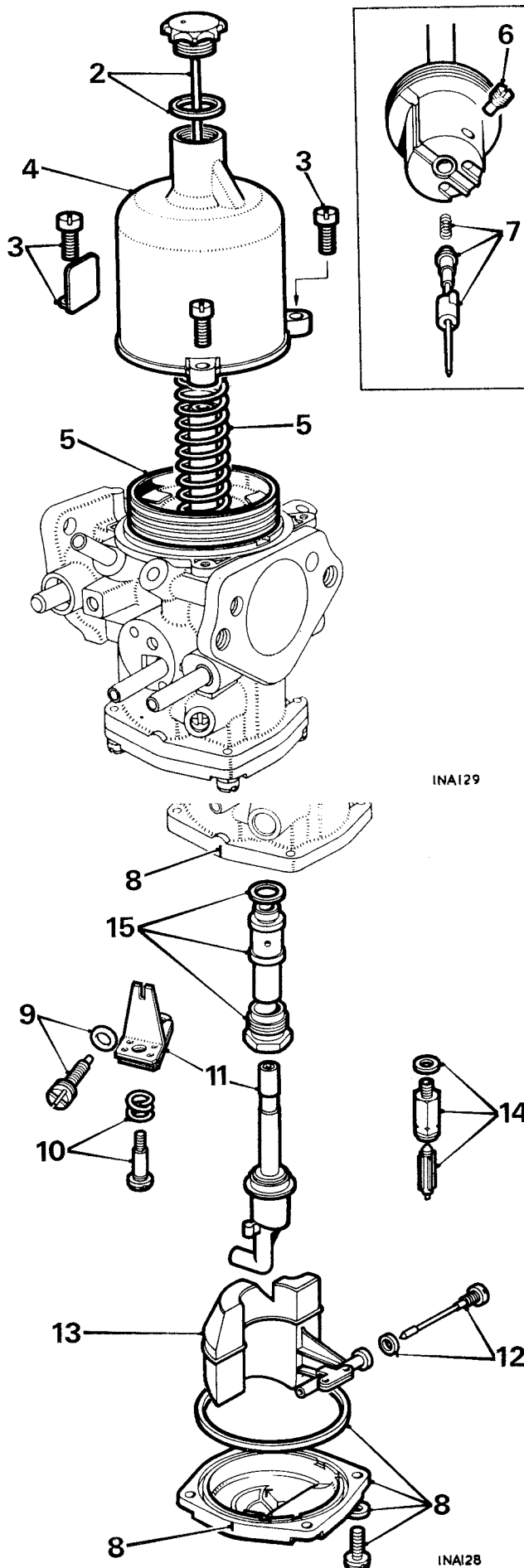

- (8) Mark the bottom cover-plate and body to ensure correct reassembly, unscrew the retaining screws and remove the cover complete with sealing ring.
- (9) Remove the jet adjusting screw complete with 'O' ring.
- (10) Remove the jet adjusting lever retaining screw and spring.
- (11) Withdraw the jet complete with adjusting lever and disengage the lever.
- (12) Remove the float pivot spindle and fibre washer.
- (13) Withdraw the float.
- (14) Remove the needle valve and unscrew the valve seat.
- (15) Unscrew the jet bearing locking nut and withdraw the bearing complete with fibre washer.

CARBURETTERS

- (16) Note the location of the ends of the fast idle cam lever return spring.
- (17) Unlock and remove the cam lever retaining nut and locking washer.
- (18) With the return spring held towards the carburetter body, prise off the cam lever and remove the return spring.
- (19) Unscrew the starter unit retaining screws and remove the cover-plate.
- (20) Withdraw the starter unit assembly and remove its gasket.
- (21) Withdraw the valve spindle and remove the 'O' ring, seals and dust cap.
- (22) Note the location and loading of the ends of the throttle lever return spring and remove the spring.
- (23) Unlock and remove the nut and tab washer retaining the throttle levers.
- (24) Remove the throttle lever and throttle actuating lever.
- (25) Remove the throttle disc retaining screws.
- (26) Open the throttle; note that the throttle disc is oval, and carefully withdraw the disc from the throttle spindle. Do not damage the over-run valve.
- (27) Withdraw the throttle spindle and remove its seals.

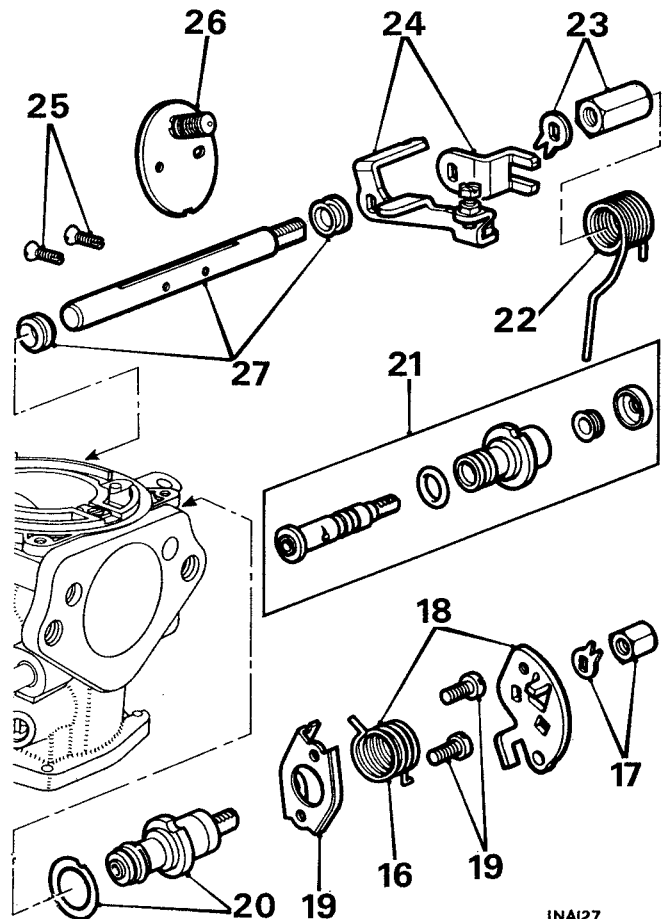

INA127

INSPECTION

- (28) Examine the throttle spindle and its bearings in the carburetter body; check for excessive play, and renew parts as necessary.
- (29) Examine the float needle and seating for damage and excessive wear; renew if necessary.
- (30) Examine all rubber seals and 'O' rings for damage deterioration; renew as necessary. The cover-plate sealing ring must be renewed.
- (31) Check condition of all fibre washers and gaskets renew as necessary.
- (32) Clean the inside of the suction chamber and piston rod guide with fuel or methylated spirit (denatured alcohol) and wipe dry. Abrasives must not be used.
- (33) Examine the carburetter body for cracks and damage and for security of the brass connections and the piston key.

NOTE.—It is only necessary to carry out the following timing check if the cause of the carburetter malfunction which necessitated the dismantling has not been located.

- (34) Temporarily plug the piston transfer holes.
- (35) Fit the piston into the chamber without its spring.
- (36) Fit a nut and screw, with a large flat washer under the screw head, into one of the suction chamber fixing holes, positioning the washer so that it overlaps the chamber bore.
- (37) Fit the damper and washer.
- (38) Check that the piston is fully home in the chamber, invert the assembly to allow the chamber to fall away until the piston contacts the washer,

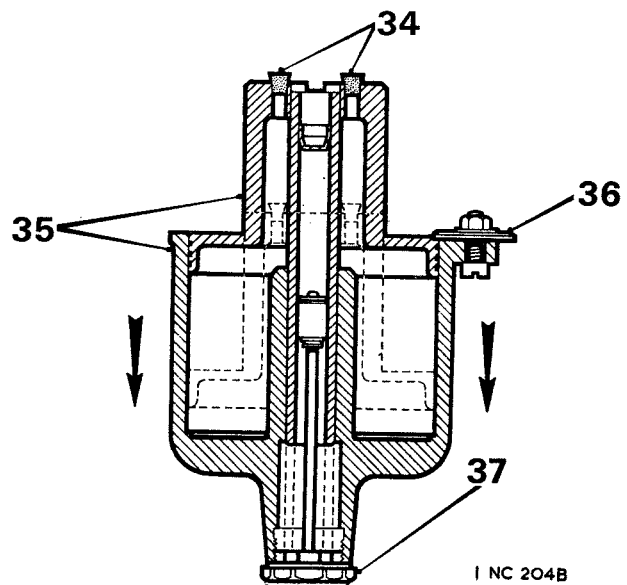

I NC 204B

CARBURETTERS

- (39) Check the time taken for the chamber to fall the full extent of the piston travel. For HIF carburetters $1\frac{1}{2}$ in. (38 mm.) bore the time taken should be 4 to 6 seconds; for HIF6 $1\frac{3}{8}$ in. (44.5 mm.) bore the time taken should be 5 to 7 seconds.
- (40) If the times are exceeded, check the piston and chamber for cleanliness and damage. If after re-checking the time is still not within these limits, renew the chamber and piston assembly.

Reassembling

- (41) Reverse the procedure in 1 to 28, noting the following:
- (a) The throttle spindle must be fitted with the threaded end at the piston lifting pin side of the body.
 - (b) Fit the throttle disc so that the over-run valve is at the top of the bore and its spring towards the inside when the throttle is closed.
 - (c) New throttle disc retaining screws must be used when refitting the disc. Ensure that the throttle disc is correctly positioned and closes correctly before tightening and locking the retaining screw.
 - (d) Position the throttle spindle end seals just below the spindle housing flange.
 - (e) The starter unit valve is fitted with the cut-out towards the top retaining screw hole, and its retaining plate is positioned with the slotted flange towards the throttle spindle.
 - (f) After fitting the float and valve, invert the carburetter so that the needle valve is held in the shut position by the weight of the float only. Check that the point indicated on the float (see illustration) is 0.04 ± 0.02 in. (1.0 ± 0.5 mm.) below the level of the float chamber face. Adjust the float position by carefully bending the arm.
 - (g) Check that the small diameter of the jet adjusting screw engages the slot in the adjusting lever and set the jet flush with the bridge of the body.
 - (h) Use a new retaining screw when refitting the needle and ensure that the needle guide etch mark aligns correctly with the piston transfer holes (see illustration). After fitting the needle assembly, check that the shoulder of the needle aligns the full face of the piston.

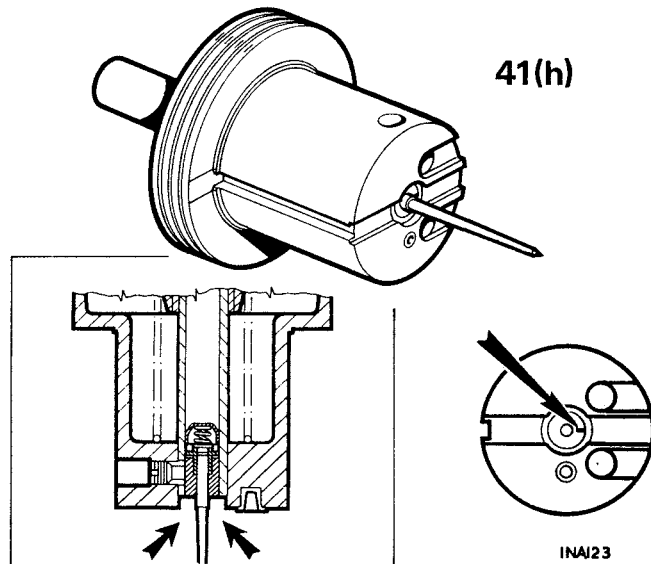
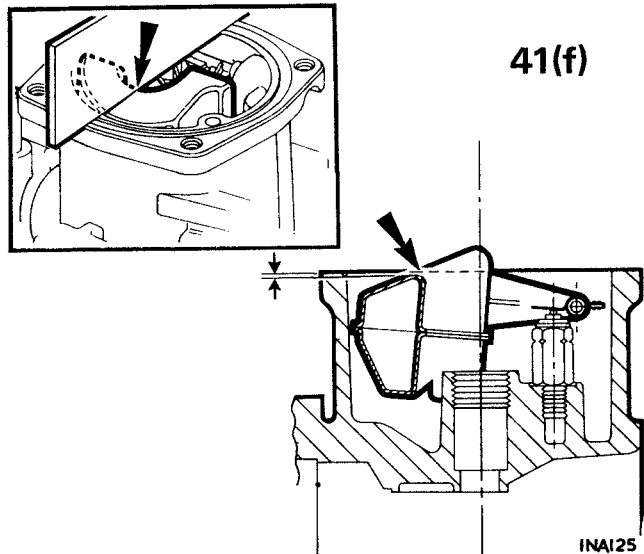

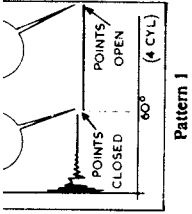
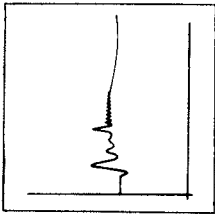
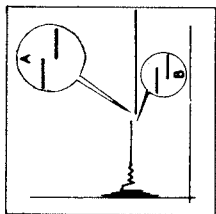
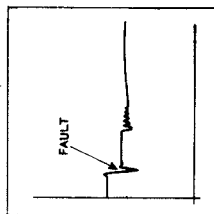
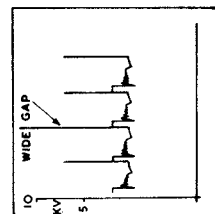
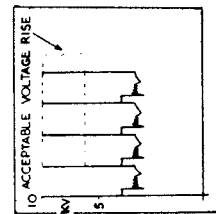
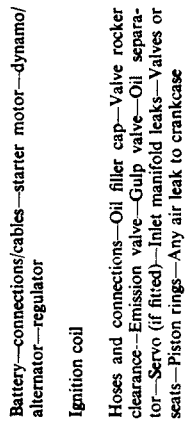
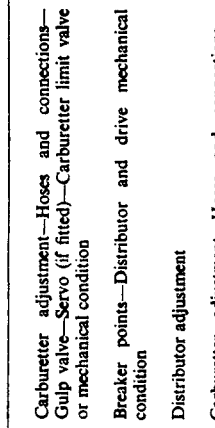
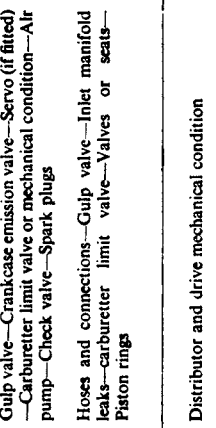
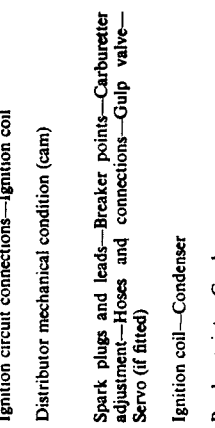
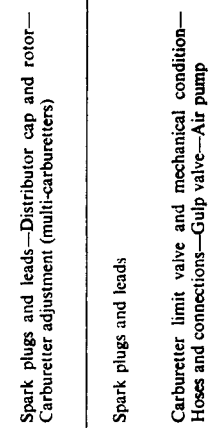
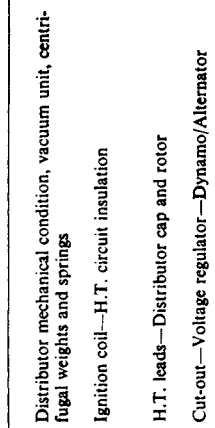
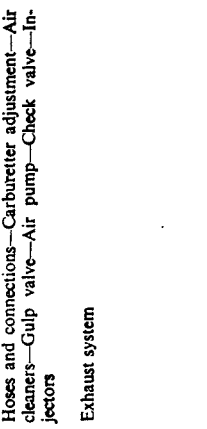
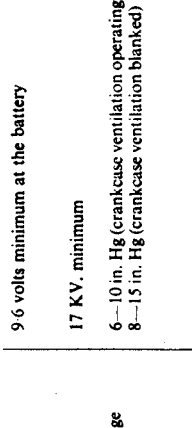
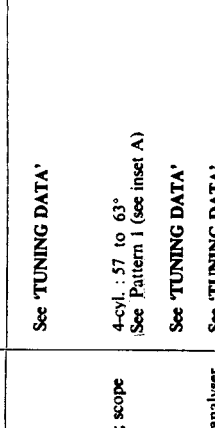
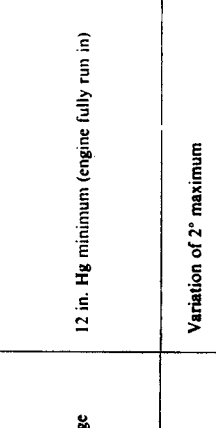
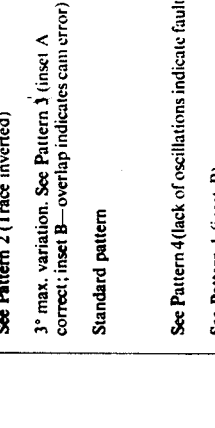
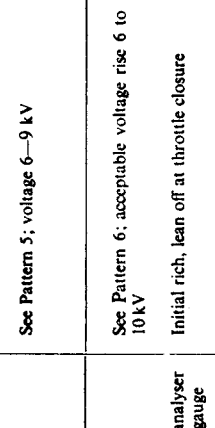
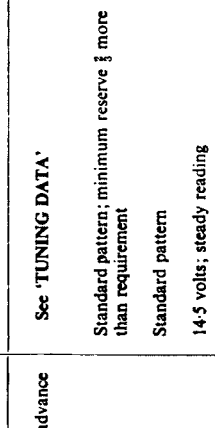
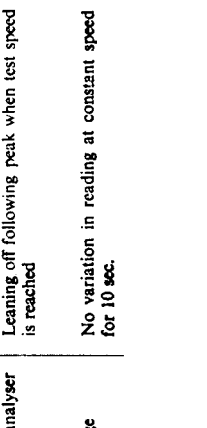
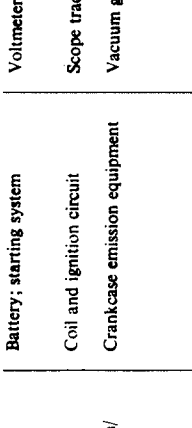
START (cranking)	Cranking voltage	Battery; starting system	Voltmeter	9.6 volts minimum at the battery 17 KV. minimum 6-10 in. Hg (crankcase ventilation operating) 8-15 in. Hg (crankcase ventilation blanked)	Battery—connections/cables—starter motor—dynamo/alternator—regulator Ignition coil Hoses and connections—Oil filler cap—Valve rocker clearance—Emission valve—Gulp valve—Oil separator—Servo (if fitted)—Inlet manifold leaks—Valves or seats—Piston rings—Any air leak to crankcase	
	Cranking coil output Positive crankcase ventilation/ cranking vacuum	Coil and ignition circuit Crankcase emission equipment	Scope trace Vacuum gauge			
IDLING (see 'TUNING DATA')	Idle speed	Carburettor idle setting	Tachometer	See 'TUNING DATA'	Carburettor adjustment—Hoses and connections—Gulp valve—Servo (if fitted)—Carburettor limit valve or mechanical condition	
	Dwell	Distributor/drive; points	Dwell meter; scope	4-cyl.: 57 to 63° See Pattern 1 (see inset A)	Breaker points—Distributor and drive mechanical condition	
	Initial timing	Spark timing setting	Timing light	See 'TUNING DATA'	Distributor adjustment	
	Fuel mixture	Carburettor setting	Exhaust gas analyser	See 'TUNING DATA'	Carburettor adjustment—Hoses and connections—Gulp valve—Crankcase emission valve—Servo (if fitted)—Carburettor limit valve or mechanical condition—Air pump—Check valve—Spark plugs	
FAST IDLE (see 'TUNING DATA')	Manifold vacuum	Engine idle efficiency	Vacuum gauge	12 in. Hg minimum (engine fully run in)	Hoses and connections—Gulp valve—Inlet manifold leaks—carburettor limit valve—Valves or seats—Piston rings	
	Dwell variation	Distributor mechanical	Dwell meter	Variation of 2° maximum	Distributor and drive mechanical condition	
	Coil polarity	Ignition circuit polarity	Scope trace	See Pattern 2 (Trace inverted)	Ignition circuit connections—Ignition coil	
	Cam lobe accuracy	Distributor cam	Scope trace	3° max. variation. See Pattern 3 (inset A correct; inset B—overlap indicates cam error)	Distributor mechanical condition (cam)	
ACCELERATE— DECELERATE	Secondary circuit	Plugs; leads; cap; rotor	Scope trace	Standard pattern	Spark plugs and leads—Breaker points—Carburettor adjustment—Hoses and connections—Gulp valve—Servo (if fitted)	
	Coil and condenser condition	Coil windings; condenser	Scope trace	See Pattern 4 (lack of oscillations indicate fault)	Ignition coil—Condenser	
	Breaker point condition	Points closing/opening/bounce	Scope trace	See Pattern 1 (inset B)	Breaker points—Condenser	
	Spark plug firing voltage	Fuel mixture; compression; plug/rotor gaps	Scope trace	See Pattern 5; voltage 6-9 kV	Spark plugs and leads—Distributor cap and rotor—Carburettor adjustment (multi-carburetters)	
TURNPIKE (Maximum ignition advance speed see 'TUNING DATA')	Spark plugs under load	Spark plugs	Scope trace	See Pattern 6; acceptable voltage rise 6 to 10 kV	Spark plugs and leads	
	Carburettor open/close action	Carburettor	Exhaust gas analyser and vacuum gauge	Initial rich, lean off at throttle closure	Carburettor limit valve and mechanical condition—Hoses and connections—Gulp valve—Air pump	
	Timing advance	Distributor mech./vacuum advance	Timing light/advance meter	See 'TUNING DATA'	Distributor mechanical condition, vacuum unit, centrifugal weights and springs	
	Maximum coil output	Coil; condenser; ignition primary	Scope trace	Standard pattern; minimum reserve 3 more than requirement	Ignition coil—H.T. circuit insulation	
ACCELERATE— DECELERATE	Secondary circuit insulation	H.T. cables, cap, rotor	Scope trace	Standard pattern	H.T. leads—Distributor cap and rotor	
	Charging voltage	Regulator; cut-out	Voltmeter	14.5 volts; steady reading	Cut-out—Voltage regulator—Dynamo/Alternator	
	Fuel mixture	Air cleaner, carburettor	Exhaust gas analyser	Leaning off following peak when test speed is reached	Hoses and connections—Carburettor adjustment—Air cleaners—Gulp valve—Air pump—Check valve—Injectors	
	Exhaust restriction	Exhaust system	Vacuum gauge	No variation in reading at constant speed for 10 sec.	Exhaust system	

SECTION 5

EVAPORATIVE LOSS CONTROL

												<i>Section</i>
Adsorption canister	5-B
Fuel line filter	5-C
General description	5-A
Leak testing	5-D

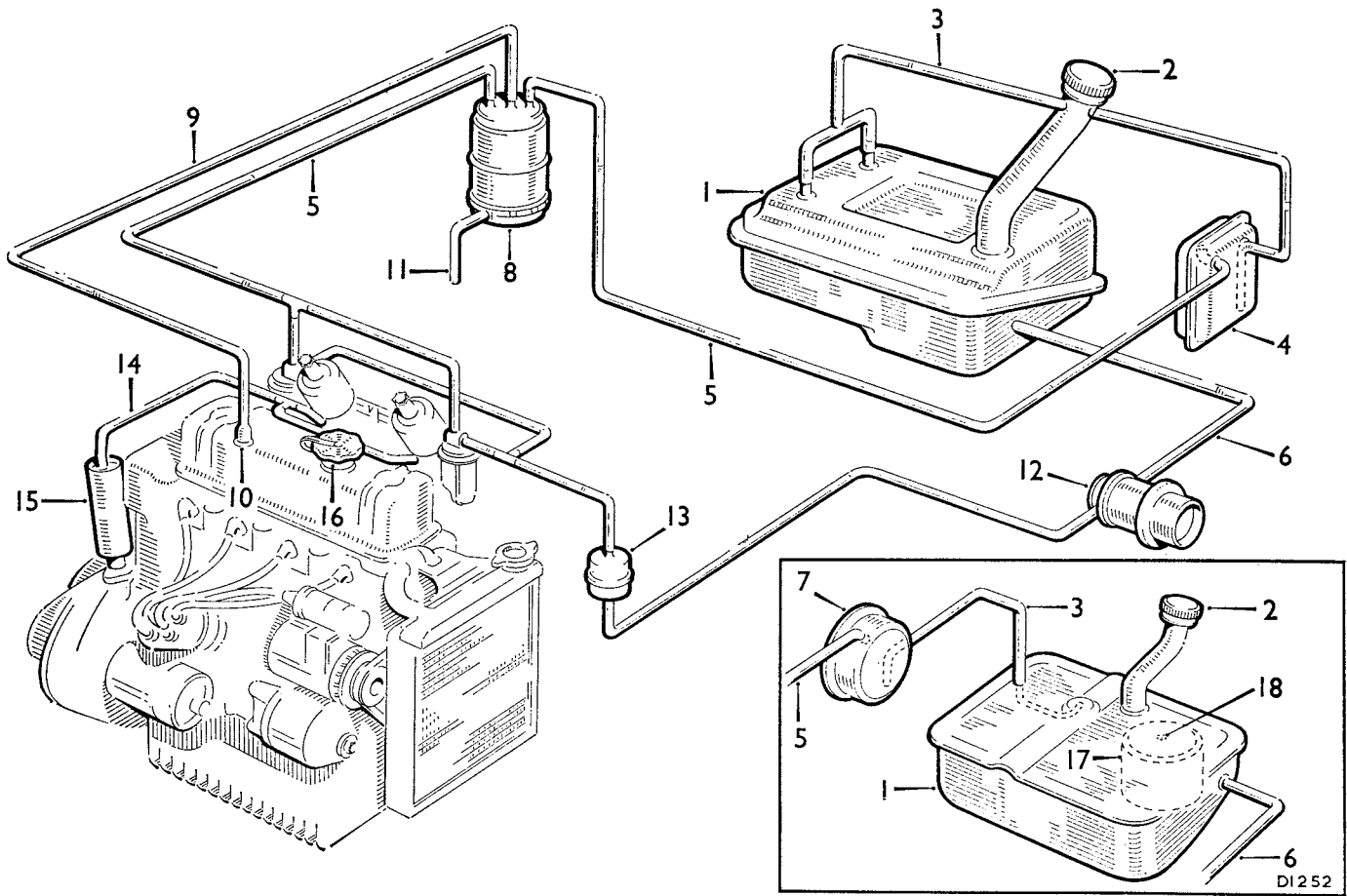

Fig. 1

A typical evaporative loss control system, with inset showing the arrangement of a separation tank and capacity-limiting fuel tank

- | | | |
|----------------------------|----------------------------|-----------------------------|
| 1. Fuel tank. | 7. Separation tank. | 13. Fuel line filter. |
| 2. Sealed fuel filler cap. | 8. Adsorption canister. | 14. Breather pipe. |
| 3. Expansion/vapour line. | 9. Purge line. | 15. Oil separator. |
| 4. Expansion tank. | 10. Restricted connection. | 16. Sealed oil filler cap. |
| 5. Vapour pipe. | 11. Air vent. | 17. Capacity limiting tank. |
| 6. Fuel pipe. | 12. Fuel pump. | 18. Air lock bleed. |

Section 5-A

GENERAL DESCRIPTION

The system is designed to collect fuel vapour evaporated from the fuel in the fuel tank, and on some twin carburettor cars from the fuel in the carburettor float-chambers. The vapour is stored in an adsorption canister while the engine is stopped, and then after the engine is restarted, passed through the crankcase emission control system to the combustion chambers. While the car is being driven the vapours are drawn directly to the crankcase emission control system.

Ventilation tubes on the fuel tank ensure that vapours are vented through the control system when the car is parked on other than a level surface.

To prevent spillage of fuel by displacement due to expansion, sufficient capacity is provided in the expansion tank to accommodate the amount of fuel from a full tank which would be displaced by a high temperature rise.

By the positioning of the expansion tank connections, or by the inclusion of a small separation tank in the vapour line, liquid fuel is prevented from being carried with the vapour to the storage canister.

IMPORTANT. The fuel and oil filler caps seal the system, and it is essential for its efficient function that they are correctly refitted after removal.

Adsorption canister

The adsorption or vapour storage canister mounted in the engine compartment contains activated charcoal (carbon) granules. Filter pads are fitted at both sides of the charcoal to filter incoming ventilating air and to prevent the granules from leaving the canister through the purge line. Provision is made for renewing the ventilation air filter pad. Vapour tubes from the fuel tank and carburettor float-chambers and the purge line from the engine breather system are connected to the ports on the

EVAPORATIVE LOSS CONTROL

top of the canister. The port on the bottom section provides a connection for the ventilating air tube.

Fuel vapour entering the canister through the vapour tubes is adsorbed and held by the charcoal. When the engine is started, air is drawn by the crankcase emission control system, through the ventilation tube and into the canister. As the air passes over the charcoal granules the vapours are given up and are carried with the air through the crankcase emission system to the combustion chambers.

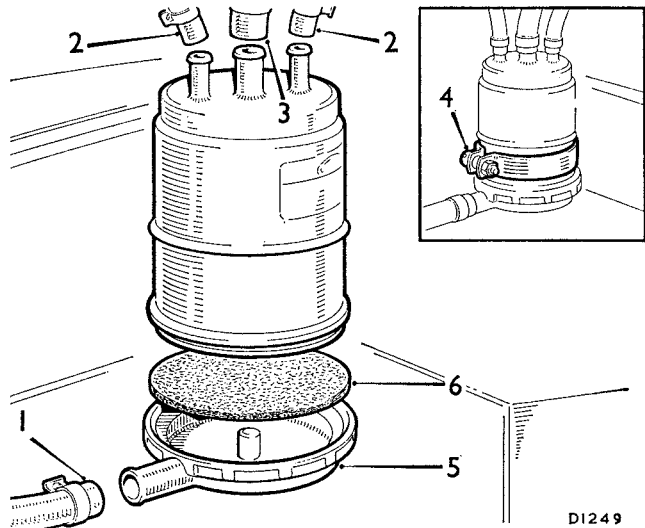

Fig. 2

The adsorption canister air filter pad

- | | |
|-------------------|----------------------------|
| 1. Air vent tube. | 4. Canister securing clip. |
| 2. Vapour pipes. | 5. End cap. |
| 3. Purge pipe. | 6. Air filter pad. |

Fuel line filter

On some models an additional renewable filter is fitted in the main fuel line as an added safeguard against foreign matter causing the setting of the carburetter float-chamber level to be exceeded.

Mixture temperature compensator

On some applications a small temperature-sensitive valve is fitted adjacent to the carburetter. The valve is connected between the air cleaner and the controlled depression chamber of the carburetter.

Under conditions where fuel is entering the carburetter at high temperature, i.e. prolonged idling in high ambient temperatures, the valve opens and allows a small quantity of air to pass into the carburetter, bypassing the jet. The air leans off the mixture which has been enriched by vapours from the evaporative loss control system and by

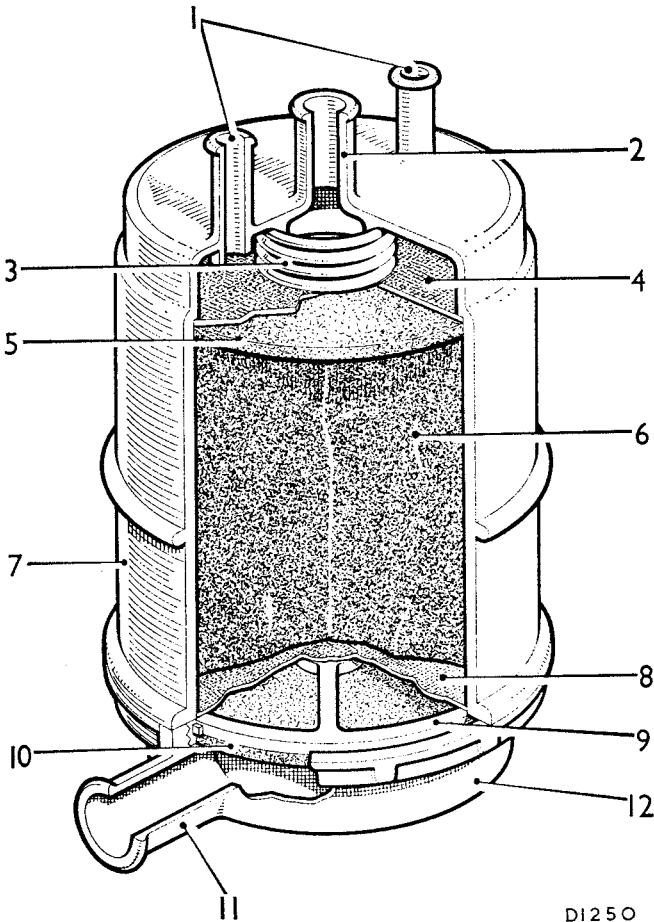

Fig. 3

The adsorption canister

- | | |
|-----------------------------|--------------------------|
| 1. Vapour pipe connections. | 7. Canister. |
| 2. Purge pipe connection. | 8. Gauze. |
| 3. Spring. | 9. Retainer. |
| 4. Gauze. | 10. Filter pad. |
| 5. Filter pad. | 11. Air vent connection. |
| 6. Charcoal granules. | 12. End cap. |

Fuel expansion

Two methods are used to ensure that sufficient space is available to accommodate fuel displaced by expansion due to high ambient temperatures. The method used on the Austin America is by fitting an additional tank into which the displaced fuel flows when the volume of the displaced fuel exceeds that of the fuel tank. The MGB and MG Midget use an air lock chamber in the fuel tank which prevents the tank being completely filled with fuel, thereby ensuring that sufficient space is always available for expansion.

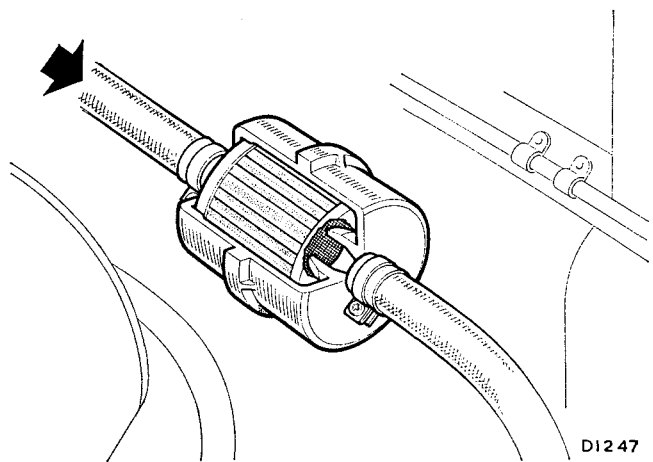

Fig. 4

The fuel line filter

EVAPORATIVE LOSS CONTROL

the increase in fuel flow through the carburettor due to the high fuel temperature.

Section 5-B

ADSORPTION CANISTER

Renewing

The air filter fitted in the bottom section of the canister must be renewed every 12,000 miles (20000 km.) or more frequently in dusty operating conditions. The complete canister must be renewed every 50,000 miles (80000 km.) or if at any time it should inadvertently become saturated with liquid fuel.

WARNING. Do not attempt to recover a saturated canister by passing compressed air through the charcoal.

- (1) Disconnect the air vent tube from the bottom of the canister.
- (2) Disconnect the vapour and purge pipes from the top of the canister.
- (3) Unscrew the securing clip screw and lift out the canister.
- (4) If the air filter pad only is being renewed:
 - (a) Unscrew the lower end cap of the canister.
 - (b) Remove and discard the filter pad.
 - (c) Clean any dirt from the cap.
 - (d) Fit the new filter pad and refit the cap.
- (5) Fit the canister ensuring that the purge pipe (from the engine rocker cover) is connected to the large centre connection on the top of the canister.

Section 5-C

FUEL LINE FILTER

Renewing

The fuel line filter must be renewed every 12,000 miles (20000 km.).

- (1) Check that the ignition is switched off.
- (2) Disconnect and discard the filter.
- (3) Connect the new filter.
- (4) Switch on the ignition and check the filter connections for fuel leakage.
- (5) Start the engine and recheck for fuel leakage.

Section 5-D

LEAK TESTING

NOTE. As a preliminary check for leaks on the induction and evaporative loss control systems on cars fitted with running on control valves, temporarily block the air vent pipe of the valve while the engine is idling. If no air leaks exist in the systems the engine will stop almost immediately; if the engine continues to run an

air leak is indicated.

If a fault in the operation is suspected or components of the system other than the filters or canister have been removed and refitted, the evaporative loss control system must be pressure-tested for leaks as follows:

- (1) Check that there is at least one gallon of fuel in the fuel tank.
- (2) Switch on the ignition for one minute to prime the fuel system.
- (3) Switch off the ignition and disconnect the fuel tank ventilation pipe from its connection on the adsorption canister.
- (4) Connect a 0 to 10 lb./sq. in. pressure gauge, a Schrader valve, and a low-pressure air supply (i.e. a tyre pump) to the disconnected pipe.
- (5) Pressurize the system until 1 lb./sq. in. is registered on the gauge. **DO NOT EXCEED THIS PRESSURE AT ANY TIME.**
- (6) Check that the gauge reading is maintained for 10 seconds without falling more than .5 lb./sq. in. If the reading is not maintained, check the system for leaks commencing with the fuel filler cap and seal.
- (7) Make a visual check for fuel leakage from the tank and its connections.
- (8) Remove the fuel filler cap and check that the gauge falls to zero.
- (9) Remove the test equipment and re-make the connections.

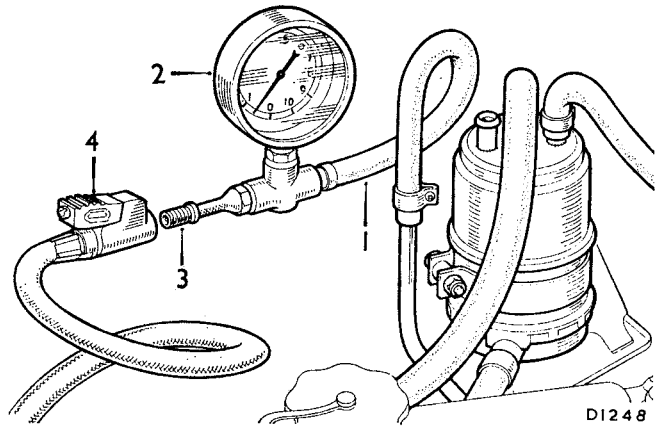

Fig. 5

Leak-testing the control system

- | | |
|--------------------------------|-----------------------------|
| 1. Fuel tank ventilation pipe. | 3. Schrader valve. |
| 2. Pressure gauge. | 4. Low-pressure air supply. |

SECTION 6

TUNING DATA

M.G. Midget	} up to 1972	6-7
Austin-Healey Sprite		6-8
M.G. Midget from 1972 on		6-8

TUNING DATA

MODEL: SPRITE (Mk. IV)/MIDGET (Mk. III) Up to 1972

ENGINE

Type	12CD or 12CJ
Firing order	1, 3, 4, 2
Capacity	1274·86 c.c. (77·8 cu. in.)
Compression ratio	8·8 : 1
Compression pressure	120 lb./sq. in. (8·44 kg./cm. ²)
Idle speed	1,000 r.p.m.
Fast idle speed	1,100 r.p.m. to 1,200 r.p.m.
Valve rocker clearance	·012 in. (·305 mm.) set cold
Stroboscopic ignition timing*	10° B.T.D.C. at 1,000 r.p.m.
Static ignition timing	4° B.T.D.C.
Timing mark location	Pointer on timing case, notch on crankshaft pulley

DISTRIBUTOR

Make	Lucas
Type	25D4
Serial number	41229 to 1971; 41271 from 1971 on
Contact breaker gap	·014 to ·016 in. (·35 to ·40 mm.)
Rotation of rotor	Anti-clockwise
Dwell angle	57° to 63°
Condenser capacity	·18 to ·24 mF
Centrifugal advance	
Crankshaft degrees*	4° at 500 to 700 r.p.m. 19° at 2,300 to 2,500 r.p.m. 30° ± 2° at 4,300 r.p.m.

Vacuum advance

Starts	5 in. Hg
Finishes	8 in. Hg
Total crankshaft degrees	6° ± 2°

SPARKING PLUGS

Make	Champion
Type	N-9Y
Gap	·024 to ·026 in. (·625 to ·660 mm.)

IGNITION COIL

Make	Lucas
Type	11C12
Resistance—primary	3 to 3·4 ohms at 20° C. (68° F.)

Consumption

Ignition on—standing	3·5 to 4 amps.
at 2,000 r.p.m.	1 amp.

CARBURETTER(S)

Make	S.U.
Type	Twin HS2
Specification—fixed needle type	AUD 266
—spring-loaded needle type	AUD 328 to 1971; AUD 404 from 1971 on
Choke diameter	1¼ in. (31·75 mm.)
Jet size	·090 in. (2·28 mm.)
Needle—fixed type	AN
—spring-loaded type	AAC
Piston spring	Blue
Initial jet adjustment	11 flats from bridge

EXHAUST EMISSION

Exhaust gas analyser reading:	
At engine idle speed	2·5% CO (maximum)
Air pump test speed	1,200 r.p.m. (engine)

* Vacuum pipe disconnected.

TUNING DATA

MODEL: M.G. MIDGET (Mk. III) from 1972 on

ENGINE

Type	12V
Firing order	1, 3, 4, 2
Capacity	1274·86 c.c. (77·8 cu. in.)
Compression ratio	8 : 1
Compression pressure	120 lb./sq. in. (8·44 kg./cm. ²)
Idle speed	1,000 r.p.m.
Fast idle speed	1,100 r.p.m. to 1,200 r.p.m.
Valve rocker clearance	·012 in. (·305 mm.) set cold
Stroboscopic ignition timing*	9° B.T.D.C. at 1,500 r.p.m.
Static ignition timing	T.D.C.
Timing mark location	Pointer on timing case, notch on crankshaft pulley

DISTRIBUTOR

Make	Lucas
Type	25D4
Serial number	1972—41369; from 1973—41400
Contact breaker gap	·014 to ·016 in. (·35 to ·40 mm.)
Rotation of rotor	Anti-clockwise
Dwell angle	57° to 63°
Condenser capacity	·18 to ·24 mF
Centrifugal advance								
Crankshaft degrees*	15° at 1,800 to 2,000 r.p.m. 24° at 2,700 to 3,100 r.p.m. 36°±2° at 4,200 r.p.m.
								<i>Serial No.</i>
Vacuum advance								41369 (1972)
Starts	4 in. Hg
Finishes	9 in. Hg
Total crankshaft degrees	16°±2°
								<i>Serial No.</i>
								41400 (1973)
								10 in. Hg
								15 in. Hg
								10°±2°

SPARKING PLUGS

Make	Champion
Type	N-9Y
Gap	·024 to ·026 in. (·625 to ·660 mm.)

IGNITION COIL

Make	Lucas
Type	11C12
Resistance—primary	3 to 3·4 ohms at 20° C. (68° F.)
Consumption								
Ignition on—standing	3·5 to 4 amps.
at 2,000 r.p.m.	1 amp.

CARBURETTER(S)

Make	S.U.
Type	Twin HS2
Specification	1972—AUD 502; from 1973—AUD 549
Choke diameter	1½ in. (31·75 mm.)
Jet size	·090 in. (2·28 mm.)
Needle	1972—AAT; from 1973—ABC
Piston spring	Blue
Initial jet adjustment	11 flats from bridge

EXHAUST EMISSION

Exhaust gas analyser reading:								
At engine idle speed	1972—3% CO (maximum); from 1973, 2·5% CO (maximum)
Air pump test speed	1,200 r.p.m. (engine)

* Vacuum pipe disconnected.